

Note : Except for the following questions, all the remaining questions have been asked in previous set.

SECTION-A

1. A bar magnet is moved in the direction indicated by the arrow between two coils PQ and CD. Predict the direction of the induced current in each coil. [1]

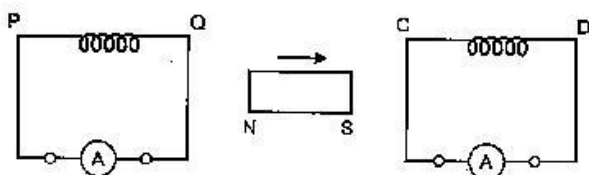

Answer : From Q to P (i.e., anticlockwise) as seen from the left end.

From C to D (i.e., clockwise) as seen from the left end.

2. Write the relation for the speed of electromagnetic waves in terms of the amplitudes of electric and magnetic fields. [1]

Answer :
$$c = \frac{E_0}{B_0}$$

7. Identify the electromagnetic waves whose wavelengths lie in the range

(a) $10^{-11} < \lambda < 10^{-14} \text{ m}$

(b) $10^{-4} \text{ m} < \lambda < 10^{-6} \text{ m}$

Write one use of each. [2]

Answer : (a) γ -rays

Use : For treatment of cancer.

(b) Infrared rays

Use : In remote control of T.V., V.C.R, etc.

9. The short wavelength limit for the Lyman series of the hydrogen spectrum is 913.4 Å. Calculate the short wavelength limit for Balmer series of the hydrogen spectrum. [2]

Answer : For short wavelength of Lyman series,

$$\frac{1}{\lambda_B} = R \left(\frac{1}{1^2} - \frac{1}{\infty^2} \right)$$

$$\frac{1}{913.4 \times 10^{-10}} = R$$

For short wavelength of Balmer series,

$$\frac{1}{\lambda_B} = R \left(\frac{1}{2^2} - \frac{1}{\infty^2} \right)$$

$$\frac{1}{\lambda_B} = \frac{1}{913.4 \times 10^{-10}} \times \frac{1}{4}$$

$$\lambda_B = 4 \times 913.4 \times 10^{-10}$$

$$\lambda_B = 3653.6 \times 10^{-10} \text{ m}$$

$$= 3653.6 \text{ \AA}$$

12. (a) Draw a ray diagram showing the formation of image by a reflecting telescope.

(b) Write two advantages of a reflecting telescope over a refracting telescope. [3]

Answer : (a)

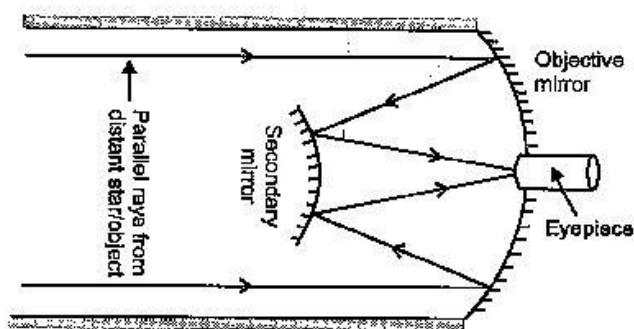

(b) 1. The image is free from chromatic aberration.

2. Spherical aberration can be eliminated by using parabolic mirror.

3. Light gathering power is more in reflecting telescope

15. Explain giving reasons for the following : [3]

(a) Photoelectric current in a photocell increases with the increase in the intensity of the incident radiation.

(b) The stopping potential (V_0) varies linearly with the frequency (ν) of the incident radiation for a given photosensitive surface with the slope remaining the same for different surfaces.

(c) Maximum kinetic energy of the photoelectrons is independent of the intensity of incident radiation.

Answer : (a) Since number of photoelectrons emitted is directly proportional to the intensity of incident radiation therefore, as intensity increases the electron-hole pairs also increases.

(b) $h\nu = h\nu_0 + eV_0$

$$eV_0 = h(\nu - \nu_0)$$

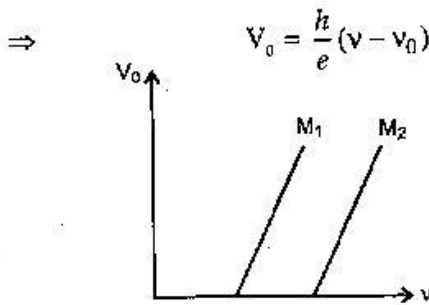

Further from graph, slope is h/e which is a constant and it does not depend on v .

$$K.E_{\text{max}} = h(v - v_0)$$

Hence, It depends on the frequency and not on the intensity of the incident radiation.

(c) As intensity increases, the number of photons increases but the energy remains same.

16. (a) In the following diagram which bulb out of B_1 and B_2 will glow and why?

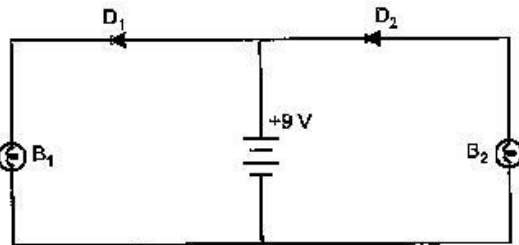

- (b) Draw a diagram of an illuminated $p-n$ junction solar cell.
 (c) Explain briefly the three processes due to which generation of emf takes place in a solar cell. [3]

Answer : (a) B_1 will glow because only diode D_1 is forward biased.

(b)

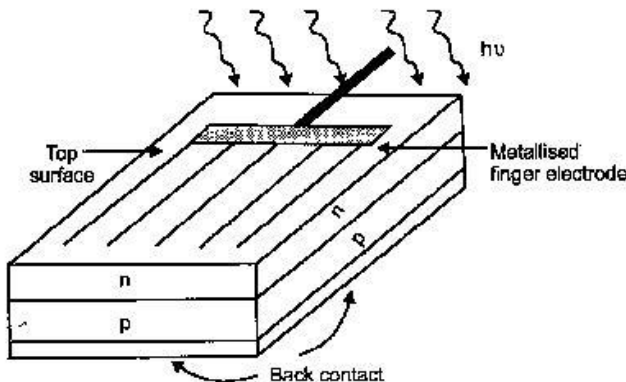

- (c) Three processes due to which generation of emf takes place in solar cell are :

1. Generation, 2. Separation, 3. Collection.

1. **Generation** : Generation of electron-hole

pairs take place due to light.

2. **Separation** : Separation of electron-hole pairs are due to electric field of depletion region.

3. **Collection** : Electrons reach the n -side and are collected in front contact and holes are collected in the back contact.

19. (a) Draw the circuit diagram for studying the characteristics of a transistor in common emitter configuration. Explain briefly and show how input and output characteristics are drawn.**

- (b) The figure shows input waveforms A and B to a logic gate. Draw the output waveform for an OR gate. Write the truth table for this logic gate and draw its logic symbol.** [3]

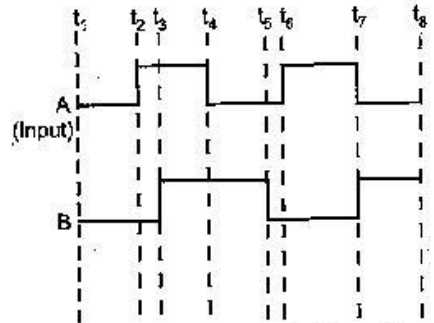

20. Two identical loops P and Q each of radius 5 cm are lying in perpendicular planes such that they have a common centre as shown in the figure. Find the magnitude and direction of the net magnetic field at the common centre of the two coils, if they carry currents equal to 3 A and 4 A respectively. [3]

Answer :

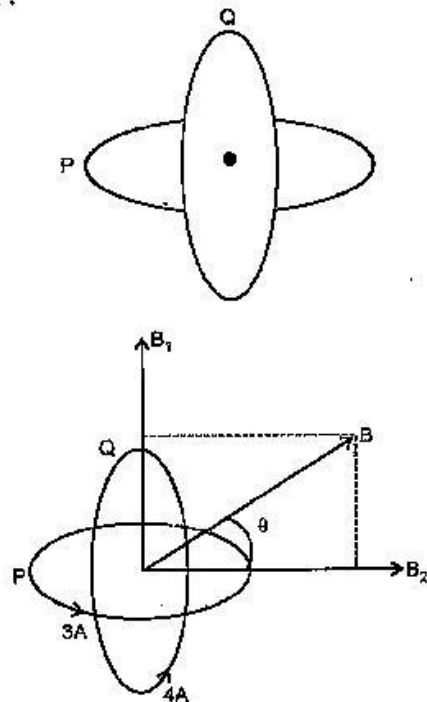

$$B_1 = \frac{\mu_0}{2R} \cdot I$$

Field due to coil P

$$(B_1) = \frac{\mu_0}{2} \times \frac{3}{5 \times 10^{-2}} \text{ tesla}$$

Similarly, Field due to coil Q

$$(B_2) = \frac{\mu_0}{2} \times \frac{4}{5 \times 10^{-2}} \text{ tesla}$$

Resultant magnetic field is,

$$B = \sqrt{B_1^2 + B_2^2}$$

$$B = \sqrt{\left(\frac{\mu_0}{2} \times \frac{3}{5 \times 10^{-2}}\right)^2 + \left(\frac{\mu_0}{2} \times \frac{4}{5 \times 10^{-2}}\right)^2}$$

$$B = \frac{\mu_0}{2 \times 5 \times 10^{-2}} \times 5$$

$$B = \frac{\mu_0}{2} \times 100 = 50 \mu_0$$

$$= 50 \times 4\pi \times 10^{-7}$$

$$= 62.83 \times 10^{-6} \text{ T}$$

Let the field make an angle θ with the vertical.

$$\tan \theta = \frac{B_1}{B_2}$$

$$\tan \theta = \frac{3}{4}$$

$$\theta = \tan^{-1} \left(\frac{3}{4} \right)$$

Thus direction of magnetic field makes an angle θ with the vertical.

••

Physics 2017 (Outside Delhi)

SET III

Time allowed : 3 hours

Maximum marks : 70

Note : Except for the following questions, all the remaining questions have been asked in the previous sets.

SECTION-A

3. What is the direction of induced currents in metal rings 1 and 2 when current I in the wire is increasing steadily? [1]

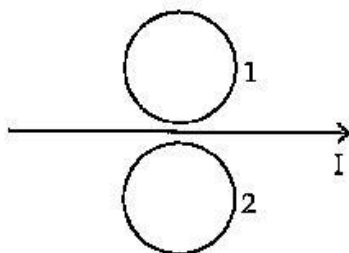

Answer : Ring - 1 \rightarrow Clockwise
Ring - 2 \rightarrow Anticlockwise

4. In which directions do the electric and magnetic field vectors oscillate in an electromagnetic wave propagating along the x-axis? [1]

Answer : Electric component \rightarrow Y - axis
Magnetic component \rightarrow Z - axis

8. Why does current in a steady state not flow in a capacitor connected across a battery? However momentary current does flow during charging or discharging of the capacitor. Explain. [2]

Answer : When there is change in the electric flux there will be a displacement current and when flux is fixed the displacement as well as conduction current will be zero.

$$I_D = \epsilon_0 \frac{d\Phi_E}{dt}$$

9. The ground state energy of hydrogen atom is -13.6 eV. If an electron makes a transition from an energy level -1.51 eV to -3.4 eV, calculate the wavelength of the spectral line emitted and name the series of hydrogen spectrum to which it belongs. [2]

Answer : When energy is -1.51 eV then $n = 3$.
When energy is -3.4 eV then $n = 2$.

$$\therefore \frac{1}{\lambda} = R \left(\frac{1}{2^2} - \frac{1}{3^2} \right)$$

$$\frac{1}{\lambda} = 1.1 \times 10^7 \left(\frac{1}{4} - \frac{1}{9} \right)$$

$$= 1.1 \times 10^7 \times \frac{5}{36}$$

$$\lambda = \frac{36}{5 \times 1.1} \times 10^{-7} \text{ m}$$

$$\lambda = 6.545 \times 10^{-7} \text{ m}$$

$$\lambda = 6545 \text{ \AA}$$

It belongs to the Balmer series.

14. (a) Draw the circuit diagram of an $n-p-n$ transistor amplifier in common emitter configuration.**

(b) Derive an expression for voltage gain of the amplifier and hence show that the output voltage is in opposite phase with the input voltage. ** [3]

17. (a) Draw a ray diagram for the formation of image by a compound microscope.

(b) You are given the following three lenses. Which two lenses will you use as an eyepiece and as an objective to construct a compound microscope ?

Lenses	Power (D)	Aperture (cm)
L ₁	3	8
L ₂	6	1
L ₃	10	1

(c) Define resolving power of a microscope and write one factor on which it depends. [3]

Answer : (a) Ray diagram for compound microscope :

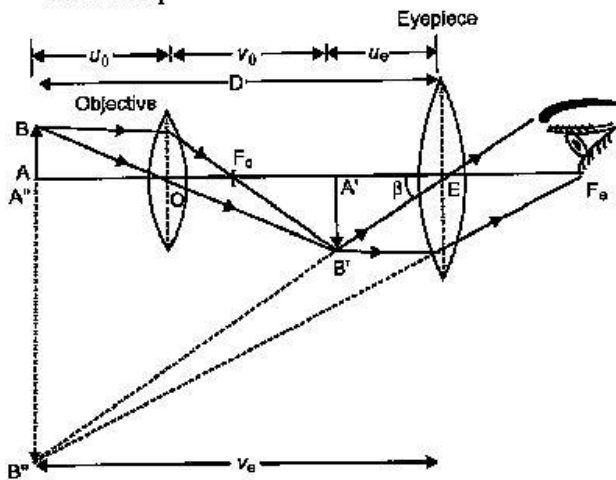

(b) Objective lens \rightarrow L₃

Eye lens \rightarrow L₂

(c) The resolving power of a microscope is its ability to form distinctly separate images of two neighbouring objects.

$$R.P. = \frac{2\mu \sin \theta}{1.22 \lambda}$$

It depends on the wavelength (λ) of the light used.

18. The following graph shows the variation of photocurrent for a photosensitive metal : [3]

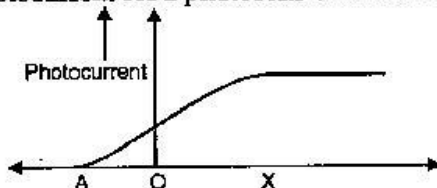

**Answers is not given due to change in the present Syllabus.

(a) Identify the variable X on the horizontal axis.

(b) What does the point A on the horizontal axis represent ?

(c) Draw this graph for three different values of frequencies of incident radiation ν_1, ν_2 and ν_3 ($\nu_1 > \nu_2 > \nu_3$) for same intensity.

(d) Draw this graph for three different values of intensities of incident radiation I_1, I_2 and I_3 ($I_1 > I_2 > I_3$) having same frequency.

Answer : (a) X is collector plate potential.

(b) Stopping potential.

(c)

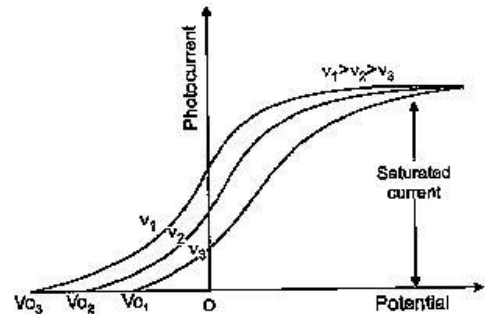

Retarding potential

(d)

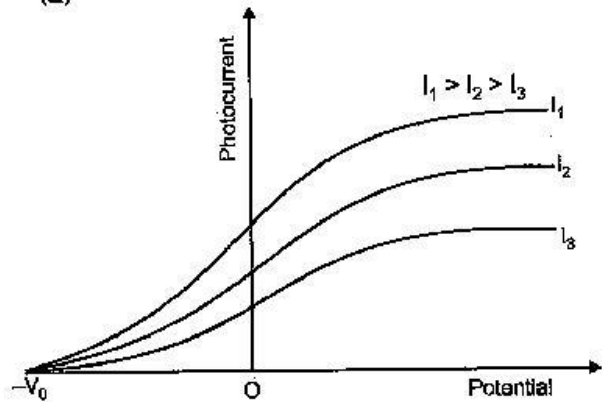

Retarding potential

21. (a) In the following diagram 'S' is a semiconductor. Would you increase or decrease the value of R to keep the reading of the ammeter A constant when S is heated ? Give reason for your answer.

(b) Draw the circuit diagram of a photodiode and explain its working. Draw its I - V characteristics. [3]

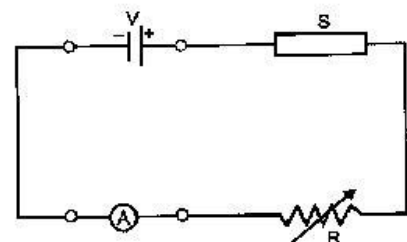

Answer: (a) The value of R has to be increase because on heating, the conductivity of a semiconductor increases. *i.e.* resistance of S decreases on heating.
(b)

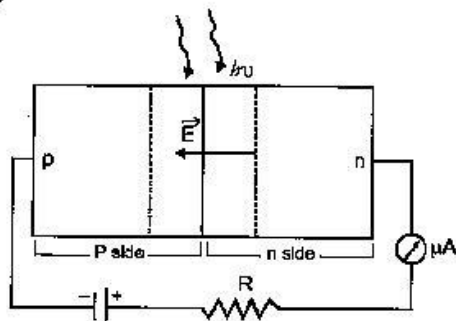

Working : In photodiode an electric field exists across the junction from n-side to p-side. When visible light with energy $h\nu$ greater

than energy gap (E_g) illuminates the junction, then electron-hole pairs are generated in the depletion layer. Due to electric field electron moves towards n side and holes towards p-side give rise to an emf. when an external load is connected current flows.

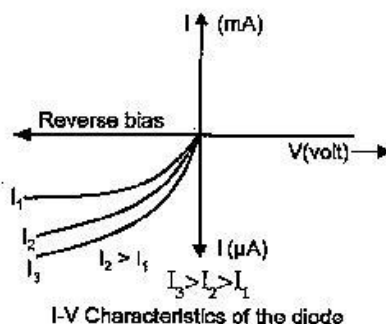

Physics 2017 (Delhi)

SET I

Time allowed : 3 hours

Maximum marks : 70

SECTION - A

1. Does the charge given to a metallic sphere depend on whether it is hollow or solid ? Give reason for your answer. [1]

Answer : No, because all the charge resides on the surface of the sphere only.

2. A long straight current carrying wire passes normally through the centre of circular loop. If the current through the wire increases, will there be an induced emf in the loop ? Justify. [1]

Answer : No, the emf will not be induced as the magnetic field lines are parallel to the plane of the circular loop. So magnetic flux will remain zero.

$$\phi = BA \cos \theta = BA \cos 90^\circ = 0$$

Hence, induced emf, $\varepsilon = -\frac{d\phi}{dt} = 0$

3. At a place, the horizontal component of earth's magnetic field is B and angle of dip is 60° . What is the value of horizontal component of the earth's magnetic field at equator ? [1]

Answer :

$$B_H = B' \cos 60^\circ$$

$$B = B' \cos 60^\circ \text{ (given } B_H = B)$$

$$B = B' \left(\frac{1}{2} \right)$$

$$B' = 2B$$

At equator,

$$\theta = 0^\circ$$

$$\begin{aligned} B_H &= B' \cos \theta \\ &= B' \cos 0^\circ \\ &= 2B \end{aligned}$$

4. Name the junction diode whose I-V characteristics are drawn below : [1]

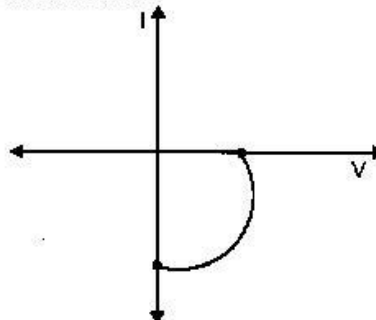

Answer : This is the characteristic of solar cell.

5. How is the speed of em-waves in vacuum determined by the electric and magnetic fields? [1]

Answer : The speed of em waves are determined by the ratio of the peak values of electric and magnetic field vectors.

$$c = \frac{E_0}{B_0}$$

SECTION-B

6. How does Ampere-Maxwell law explain the flow of current through a capacitor when it is being charged by a battery ? Write the expression for the displacement current in terms of the rate of change of electric flux. [2]

Answer : During the charging of capacitor, (electric flux between the plates of capacitor keeps on changing, due to which displacement current between the plates is produced. Hence circuit becomes complete and current flow through the circuit.

$$I_D = \epsilon_0 \frac{d\phi_E}{dt}$$

7. Define the distance of closest approach. An α -particle of kinetic energy 'K' is bombarded on a thin gold foil. The distance of the closest approach is 'r'. What will be the distance of closest approach for an α -particle of double the kinetic energy? [2]

OR

Write two important limitations of Rutherford nuclear model of the atom.

Answer : It is defined as the minimum distance of the charged particle from the nucleus at which initial kinetic energy of the particle is equal to the potential energy due to the charged nucleus.

At this distance, K.E = P.E

$$K = \frac{1}{4\pi\epsilon_0} \frac{Ze(2e)}{r}$$

$$r = \frac{1}{4\pi\epsilon_0} \frac{2Ze^2}{K} \quad \dots(i)$$

If K is doubled,

$$r' = \frac{1}{4\pi\epsilon_0} \frac{2Ze^2}{2K} \quad \dots(ii)$$

Dividing (ii) by (i), we get

$$\frac{r'}{r} = \frac{1}{2}$$

$$\Rightarrow r' = \frac{r}{2}$$

OR

Limitations : (a) It is not in accordance with the Maxwell's theory and could not explain the stability of an atom.

(b) It did not say anything about the arrangement of electrons in an atom.

8. Find out the wavelength of the electron orbiting in the ground state of hydrogen atom. [2]

Answer : We know that, according to de Broglie relation,

$$2\pi r = n\lambda$$

For first orbit, $n = 1$

$$2\pi r = n\lambda$$

$$\lambda = 2\pi \times 0.53 \text{ \AA} \quad [\because r = 0.53 \text{ \AA}]$$

$$\lambda = 3.331 \text{ \AA}$$

9. Define the magnifying power of a compound microscope when the final image is formed at

infinity. Why must both the objective and the eyepiece of a compound microscope has short focal lengths? Explain. [2]

Answer : Magnifying Power : The magnifying power of a compound microscope is defined as the ratio of the angle subtended at the eye by the final image to the angle subtended at the eye by the object, when both the final image and the object are situated at the least distance of distinct vision from the eye.

Magnifying power of the compound microscope when the final image is at infinity,

$$m = -\frac{L}{f_0} \times \frac{D}{f_e}$$

From the above equation, we can see that to achieve a large magnification, the objective and eyepiece should have small focal lengths.

10. Which basic mode of communication is used in satellite communication? What type of wave propagation is used in this mode? Write, giving reason, the frequency range used in this mode of propagation. [2]

SECTION - C

11. (a) Find the value of the phase difference between the current and the voltage in the series LCR circuit shown below. Which one leads in phase : current or voltage? (b) Without making any other change, find the value of the additional capacitor C_v to be connected in parallel with capacitor C, in order to make the power factor of the circuit unity. [3]

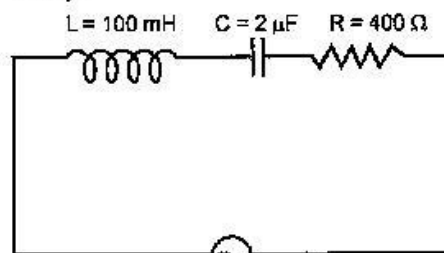

$$V = V_0 \sin(1000t + \phi)$$

Answer : (a) Given :

$$L = 100 \times 10^{-3} \text{ H}$$

$$C = 2 \times 10^{-6} \text{ F}$$

$$R = 400 \text{ } \Omega$$

$$\omega = 1000$$

Now,

$$X_L = \omega L$$

$$X_L = (1000 \times 100 \times 10^{-3}) \text{ } \Omega$$

$$X_L = 100 \text{ } \Omega$$

And

$$X_C = \frac{1}{\omega C}$$

$$= \frac{1}{1000 \times 2 \times 10^{-6}}$$

$$= \frac{10^6}{2 \times 10^3}$$

$$X_C = \frac{1000}{2} = 500 \Omega$$

Here $X_C > X_L$ so, the current will lead.

$$\tan \phi = \frac{X_L - X_C}{R}$$

$$= \frac{100 - 500}{400}$$

$$\tan \phi = -\frac{400}{400}$$

$$\tan \phi = -1$$

\Rightarrow phase angle $\phi = -45^\circ$

(b) For unity power factor,

$$X_L = X_C$$

$$\omega L = \frac{1}{\omega C_{eq}}$$

$$\omega^2 = \frac{1}{LC_{eq}}$$

$$C_{eq} = \frac{1}{L\omega^2}$$

$$C_{eq} = \frac{1}{(1000)^2 \times 100 \times 10^{-3}} = 10 \mu F$$

Now,

$$C_{eq} = C + C_1$$

$$10 = 2 + C_1$$

$$10 - 2 = C_1$$

$$C_1 = 8 \mu F$$

12. Write the two processes that take place in the formation of a $p-n$ junction. Explain with the help of a diagram, the formation of depletion region and barrier potential in a $p-n$ junction. [3]

Answer : Two important processes involved during the formation of $p-n$ junction are diffusion and drift. Electron diffusion

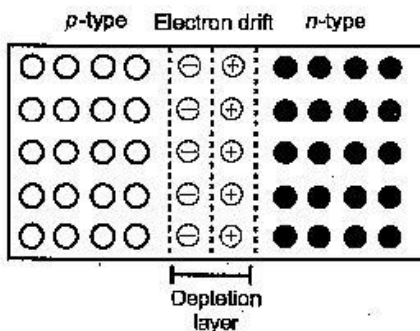

Formation of depletion region and barrier potential : At the instant of $p-n$ junction formation, the free electrons near the junction diffuse across

the junction into the p region and combines with holes. Thus, on combining with the hole, it makes a negative ion and leaves a positive ion on n -side. These two layers of immobile positive and immobile negative charges form the depletion region.

Further, as electrons diffuse across the junction a point is reached where the negative charge repels any further diffusion of electron. This depletion region now acts as a barrier. Now the external energy is supplied to get the electrons to move across the barrier of electric field. The potential difference required to move the electrons through the electric field is called barrier potential.

13. (a) Obtain the expression for the cyclotron frequency.
 (b) A deuteron and a proton are accelerated by the cyclotron. Can both be accelerated with the same oscillator frequency? Give reason to justify your answer. [3]

Answer : (a) Suppose the positive ion with charge q moves in a dee with a velocity v , then

$$\frac{mv^2}{r} = qvB$$

$$r = \frac{mv}{qB} \quad (i)$$

where m is the mass and r is the radius of the path of ion in the dee and B is the strength of the magnetic field.

The time taken by the ion,

$$T = \frac{2\pi r}{v}$$

$$\frac{1}{f} = \frac{2\pi r}{v}$$

$$f = \frac{v}{2\pi r}$$

$$f = \frac{v}{2\pi \times mv} \text{ [using (i)]}$$

This frequency is called the cyclotron frequency.

(b) Deuteron and proton have different masses and cyclotron frequency depends inversely on mass. Hence, cannot be accelerated with the same oscillator frequency.

14. (a) How does one explain the emission of electrons from a photosensitive surface with the help of Einstein's photoelectric equation?
 (b) The work function of the following metals is given : Na = 2.75 eV, K = 2.3 eV, Mo = 4.17 eV and Ni = 5.15 eV. Which of these metals will not cause photoelectric emission for radiation of wavelength 3300 Å from a laser source placed 1 m away from these metals? What happens if the laser source is brought nearer and placed 50 cm away? [3]

Answer: (a) According to Einstein's photoelectric equation,

$$\begin{aligned}
 hv &= hv_0 + E_{\text{max}} \\
 E_{\text{max}} &= hv - hv_0 \\
 E_{\text{max}} &= h(v - v_0)
 \end{aligned}$$

If $v < v_0$ then E_{max} will be negative so, no emission takes place.

If $v > v_0$ then E_{max} will be positive and directly proportional to v so, emission takes place.

(b)
$$E = \frac{hc}{\lambda}$$

$$E = \frac{6.63 \times 10^{-34} \times 3 \times 10^8}{3300 \times 10^{-10} \times 1.6 \times 10^{-19}}$$

$$E = 3.76 \text{ eV}$$

The work function of Na and K is less than the energy of incident radiation.

Therefore, Na and K will cause photoelectric emission while Mo and Ni will not cause photoelectric emission.

There will be no effect on photoelectric emission if the source is brought nearer.

15. A resistance of R draws current from a potentiometer. The potentiometer wire, AB, has a total resistance of R_0 . A voltage V is supplied to the potentiometer. Derive an expression for the voltage across R when the sliding contact is in the middle of potentiometer wire. [3]

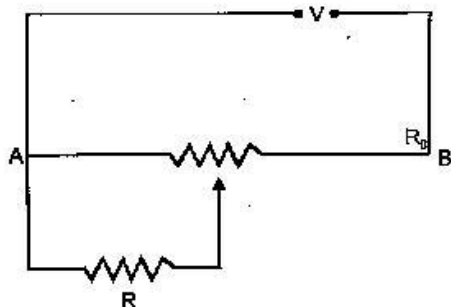

Answer :

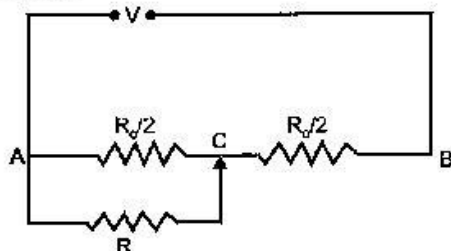

The equivalent resistance between A and C,

$$\frac{1}{2} = \frac{1}{2} + \frac{1}{R_0/2}$$

$$R' = \frac{R \cdot \frac{R_0}{2}}{R + \frac{R_0}{2}} = \frac{RR_0}{2R + R_0} \quad \dots(i)$$

Equivalent resistance between A and B,

$$R_{\text{eq}} = \frac{RR_0}{2R + R_0} + \frac{R_0}{2}$$

$$R_{\text{eq}} = \frac{R_0(4R + R_0)}{2(2R + R_0)} \quad \dots(ii)$$

Current in the circuit,

$$I = \frac{V}{R_{\text{eq}}} = \frac{V \cdot 2(2R + R_0)}{R_0(4R + R_0)}$$

\therefore Voltage across R ,

$$V_R = IR'$$

$$V_R = \frac{V \cdot 2(2R + R_0)}{R_0(4R + R_0)} \times \frac{RR_0}{(2R + R_0)}$$

$$V_R = \frac{2VR}{4R + R_0}$$

16. Define the term 'amplitude modulation.' Explain any two factors which justify the need for modulating a low frequency base-band signal.** [3]

17. (a) Find equivalent capacitance between A and B in the combination given below. Each capacitor is of $2\mu\text{F}$ capacitance.

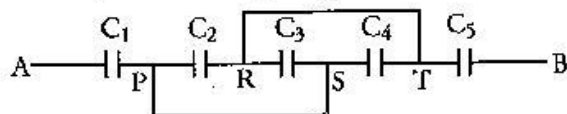

- (b) If a dc source of 7 V is connected across AB, how much charge is drawn from the source and what is the energy stored in the network? [3]

Answer : (a) In the given figure, C_2 , C_3 and C_4 are in parallel so, the equivalent capacitance of parallel capacitors is given by C' .

$$C' = C_2 + C_3 + C_4 = (2 + 2 + 2) \mu\text{F}$$

$$C' = 6 \mu\text{F}$$

Again, C_1 , C' and C_5 are in series. Therefore, the equivalent capacitance C_{eq} is given by

$$\frac{1}{C_{\text{eq}}} = \frac{1}{2} + \frac{1}{6} + \frac{1}{2}$$

$$\frac{1}{C_{\text{eq}}} = \frac{3+1+3}{6} = \frac{7}{6}$$

$$C_{\text{eq}} = \frac{6}{7} \mu\text{F}$$

- (b) The charge remains same in series circuit.

$$Q = C_{eq} V$$

$$= \frac{6}{7} \times 7$$

$$Q = 6 \mu F$$

Now, $U = \frac{1}{2} C_{eq} V^2$

$$U = \frac{1}{2} \times \frac{6}{7} \times (7)^2 \times 10^{-6}$$

$$U = 21 \times 10^{-6} \text{ joule} = 21 \mu J$$

18. (a) Derive the expression for electric field at a point on the equatorial line of an electric dipole.

(b) Depict the orientation of the dipole in (i) stable, (ii) unstable equilibrium in a uniform electric field. [3]

Answer : (a) Consider a point P on broad side position of dipole formed of charges $+q$ and $-q$ at separation $2l$. The distance of point P from mid point (O) of electric dipole is r . Let \vec{E}_1 and \vec{E}_2 be the electric field strengths due to charges $+q$ and $-q$ of electric dipole.

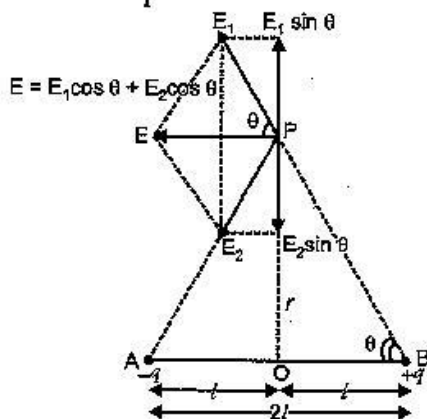

From the figure, $AP = BP = \sqrt{r^2 + l^2}$

$$\therefore \vec{E}_1 = \frac{1}{4\pi\epsilon_0} \frac{q}{r^2 + l^2} \text{ along B to P}$$

$$\vec{E}_2 = \frac{1}{4\pi\epsilon_0} \frac{q}{r^2 + l^2} \text{ along P to A}$$

The components of \vec{E}_1 and \vec{E}_2 perpendicular to AB : $E_1 \sin \theta$ and $E_2 \sin \theta$ being equal and opposite cancel each other, while the cosine components of \vec{E}_1 and \vec{E}_2 parallel to AB : $E_1 \cos \theta$ and $E_2 \cos \theta$ being in the same direction add up and give the resultant electric field whose direction is parallel to BA.

\therefore Resultant electric field at P is $E = E_1 \cos \theta + E_2 \cos \theta$

But $E_1 = E_2 = \frac{1}{4\pi\epsilon_0} \frac{q}{(r^2 + l^2)}$

From the figure, $\cos \theta = \frac{OB}{PB} = \frac{l}{\sqrt{r^2 + l^2}}$

$$= \frac{l}{(r^2 + l^2)^{1/2}}$$

$$E = 2E_1 \cos \theta$$

$$= 2 \times \frac{1}{4\pi\epsilon_0} \frac{q}{(r^2 + l^2)} \cdot \frac{l}{(r^2 + l^2)^{1/2}}$$

$$= \frac{1}{4\pi\epsilon_0} \frac{2ql}{(r^2 + l^2)^{3/2}}$$

But $q \cdot 2l = p = \text{electric dipole moment}$

$$E = \frac{1}{4\pi\epsilon_0} \frac{p}{(r^2 + l^2)^{3/2}}$$

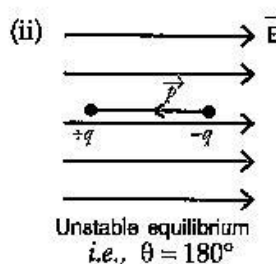
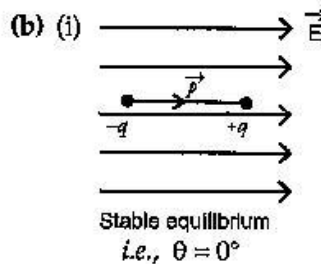

19. (a) A radioactive nucleus 'A' undergoes a series of decays as given below :

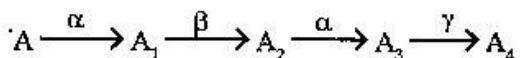

The mass number and atomic number of A_2 are 176 and 71 respectively. Determine the mass and atomic numbers of A_4 and A.

(b) Write the basic nuclear process underlying β^+ and β^- decays. [3]

Answer : (a)

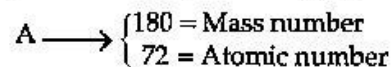
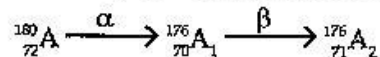
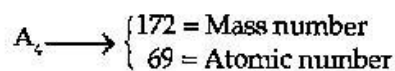
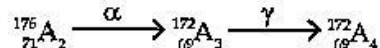
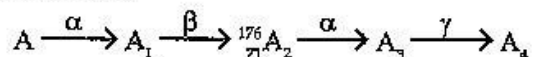

(b) The process of spontaneous emission of a positron (e^+) from nucleus is called β^+ decay.

$$p \rightarrow n + {}^0_1e + \bar{\nu}$$

The process of spontaneous emission of an electron (e^-) from nucleus is called β^- decay.

$$n \rightarrow p + {}^0_{-1}e + \bar{\nu}$$

20. (a) A ray of light incident on face AB of an equilateral glass prism, shows minimum deviation of 30° . Calculate the speed of light through the prism.

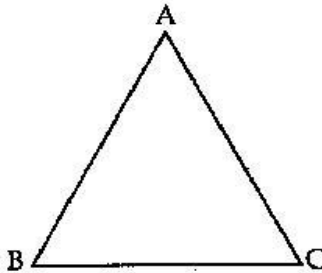

- (b) Find the angle of incidence at face AB so that the emergent ray grazes along the face AC. [3]

Answer : (a) Given :

$$\delta_m = 30^\circ$$

$$A = 60^\circ$$

Refractive index of the prism,

$$\mu = \frac{\sin\left(\frac{\delta_m + A}{2}\right)}{\sin\left(\frac{A}{2}\right)}$$

$$\mu = \frac{\sin\left(\frac{30^\circ + 60^\circ}{2}\right)}{\sin\left(\frac{60^\circ}{2}\right)}$$

$$\mu = \frac{\sin(45^\circ)}{\sin(30^\circ)}$$

$$\mu = \frac{1/\sqrt{2}}{1/2} = \frac{2}{\sqrt{2}} = \sqrt{2}$$

Now,

$$\mu = \frac{c}{v}$$

$$v = \frac{c}{\mu}$$

$$v = \frac{3 \times 10^8}{\sqrt{2}}$$

$$v = \frac{3 \times 10^8}{1.414}$$

$$v = 2.12 \times 10^8 \text{ m/s}$$

(b)

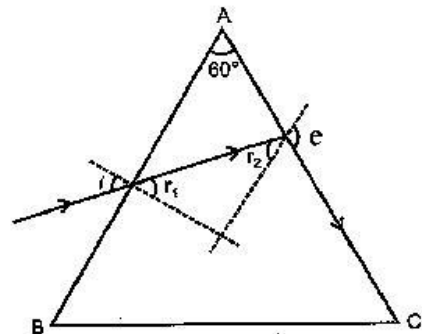

Since the light grazes along the face AC. Therefore, r_2 is the critical angle.

$$\sin r_2 = \frac{1}{\mu}$$

$$\sin r_2 = \frac{1}{\sqrt{2}}$$

$$\sin r_2 = \sin 45^\circ$$

$$r_2 = 45^\circ$$

\therefore

$$r_1 + r_2 = A$$

$$r_1 = A - r_2$$

$$= 60^\circ - 45^\circ$$

$$r_1 = 15^\circ$$

Now,

$$\mu = \frac{\sin i}{\sin r_1}$$

By snell's law

$$\sin i = \mu \sin r_1$$

$$= \sqrt{2} \sin(15^\circ)$$

$$= 1.414 \times 0.2588$$

$$\sin i = 0.366$$

$$i = 21^\circ \text{ (approx)}$$

21. For a CE-transistor amplifier, the audio signal voltage across the collector resistance of $2 \text{ k}\Omega$ is 2 V . Given the current amplification factor of the transistor is 100, find the input signal voltage and base current, if the base resistance is $1 \text{ k}\Omega$.** [3]

22. Describe the working principle of a moving coil galvanometer. Why is it necessary to use (i) a radial magnetic field and (ii) a cylindrical soft iron core in a galvanometer? Write the expression for current sensitivity of the galvanometer.

Can a galvanometer as such be used for measuring the current? Explain. [3]

OR

- (a) Define the term 'self-inductance' and write its S.I. unit.
- (b) Obtain the expression for the mutual inductance of two long co-axial solenoids S_1 and S_2 wound one over the other, each of length L and radii r_1 and r_2 and n_1 and n_2 number of turns per unit length, when a current I is set up in the outer solenoid S_2 .

Answer : Moving coil galvanometer :

Principle : It works on the principle that a current carrying coil placed in a magnetic field experiences a torque.

Radial magnetic field : It is necessary to eliminate the effect of θ on torque and hence enable us to make the scale of galvanometer linear.

Cylindrical soft iron core : It makes the magnetic lines of force pointing along the radii of the circle and also due to high permeability it intensifies the magnetic field and hence increases the sensitivity of the galvanometer.

Current sensitivity :

$$I_s = \frac{NBA}{K} \text{ or } \frac{Q}{I}$$

where Q is the deflection of coil

No, it can not be used to measure electric current because it is a highly current sensitive device which would show large deflection even with the passage of small current. And the galvanometer coil is likely to be damaged by currents in (mA/A) range.

OR

(a) **Self-inductance :** The self inductance of a coil may be defined as the induced emf set up in the coil due to a unit rate of change of current through it.

Its S.I. unit is Henry (H).

(b)

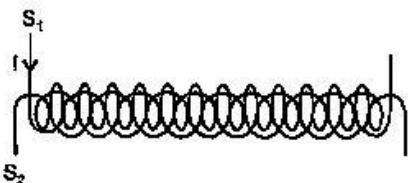

Magnetic field produced, $B = \mu_0 n_2 I$.

The flux produced in it, $\phi_1 = \mu_0 n_2 I \pi r_1^2$. [$\because \phi = BA$]

This flux is linked with all the turns of S_1 ,

$$\phi_1 = \mu_0 n_2 I \pi r_1^2 n_1 L \quad \dots (i)$$

$$\text{Also } \phi = MI \quad \dots (ii)$$

Comparing (i) and (ii), we get

$$M = \mu_0 n_1 n_2 L \pi r_1^2$$

SECTION-D

23. Mrs. Rashmi Singh broke her reading glasses. When she went to the shopkeeper to order new specs, he suggested that she should get spectacles with plastic lenses instead of glass lenses. On getting the new spectacles, she found that the new ones were thicker than the earlier ones, she asked this question to the shopkeeper but he could not offer satisfactory explanation for this. At home, Mrs. Singh raised the same question to her daughter Anuja who explained why plastic lenses were thicker. [4]

(a) Write two qualities displayed each by Anuja and her mother.**

(b) How do you explain this fact using lens maker's formula ?

Answer :

(b) According to lens maker's formula,

$$\frac{1}{f} = (n - 1) \left(\frac{1}{R_1} - \frac{1}{R_2} \right)$$

where f is the focal length, n is the refractive index and R_1 and R_2 is the radius of curvature of the lens.

Since $n_g > n_p$.

where, g stands for glass and p stands for plastic.

Therefore, we get $(n_g - 1) > (n_p - 1)$

Now, using the lens maker's formula, we see that focal length is inversely proportional to $(\mu - 1)$.

Hence, $f_p > f_g$

Thus, in the case of plastic lens the thickness of the lens should be increased to keep the same focal length as that of the glass lens to give the same power.

SECTION-E

24. (a) Draw a labelled diagram of AC generator. Derive the expression for the instantaneous value of the emf induced in the coil.
- (b) A circular coil of cross-sectional area 200 cm^2 and 20 turns is rotated about the vertical diameter with angular speed of 50 rad s^{-1} in a uniform magnetic field of magnitude $3.0 \times 10^{-2} \text{ T}$. Calculate the maximum value of the current in the coil. [5]

OR

- (a) Draw a labelled diagram of a step-up transformer. Obtain the ratio of secondary to primary voltage in terms of number of turns and currents in the two coils.
- (b) A power transmission line feeds input power at 2200 V to a step-down transformer with its primary windings having 3000 turns. Find the number of turns in the secondary to get the power output at 220 V.

Answer : (a)

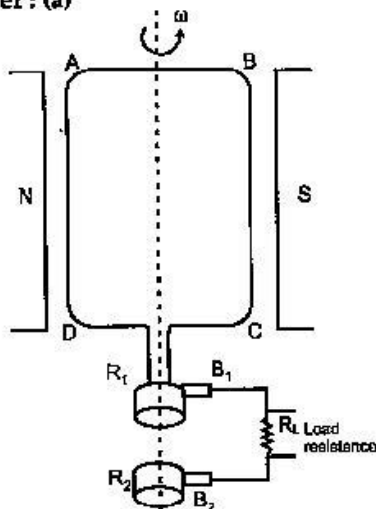

where, B_1 } are brushes.
 B_2 }
 R_1 } are slip rings.
 R_2 }
 R_L is load resistance.
 ABCD is armature.

If N is the number of turns in coil, A area of coil and B the magnetic induction then flux ϕ is given by

$$\phi = BA$$

$$\phi = BA \cos \omega t$$

When the coil is rotated with constant angular speed ' ω ' in time ' t '

The emf induced in the coil is given by,

$$e = -N \frac{d\phi}{dt} = -N \frac{d}{dt} (BA \cos \omega t)$$

$$= -NBA (-\omega \sin \omega t)$$

$$= NBA \omega \sin \omega t$$

$$e = e_0 \sin \omega t \quad (\text{where } e_0 = NBA\omega)$$

(b) We know that,

$$e_0 = NBA\omega$$

$$e_0 = 20 \times 3 \times 10^{-2} \times 200 \times 10^{-4} \times 50$$

$$e_0 = 0.6 \text{ volt} = 600 \text{ mV}$$

$$I_0 = \frac{e_0}{R}$$

$$I_0 = \frac{0.6}{R} \text{ A} = \frac{600}{R} \text{ mA}$$

OR

(a)

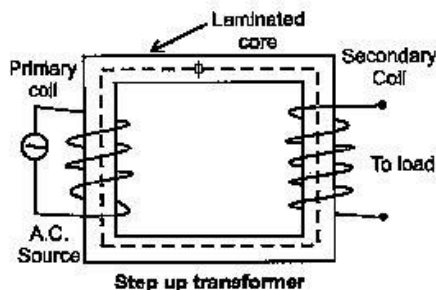

The emf induced in primary and secondary coil,

$$e_s = -N_s \frac{d\phi}{dt} \quad \dots(i)$$

$$e_p = -N_p \frac{d\phi}{dt} \quad \dots(ii)$$

Dividing (i) by (ii), we get

$$\frac{e_s}{e_p} = \frac{N_s}{N_p} \quad \dots(iii)$$

According to the law of conservation of energy in an ideal transformer,

$$e_s I_s = e_p I_p$$

$$\frac{e_s}{e_p} = \frac{I_p}{I_s} \quad \dots(iv)$$

From equation (iii) and (iv), we get

$$\frac{e_s}{e_p} = \frac{N_s}{N_p} = \frac{I_p}{I_s}$$

(b) Given :

$$e_p = 2200 \text{ V}$$

$$N_p = 3000$$

$$N_s = ?$$

$$e_s = 220 \text{ V}$$

$$\therefore \frac{e_s}{e_p} = \frac{N_s}{N_p}$$

$$\frac{220}{2200} = \frac{N_s}{3000}$$

$$\Rightarrow N_s = 300$$

25. (a) Distinguish between unpolarised light and linearly polarised light. How does one get linearly polarised light with the help of a polaroid ?

(b) A narrow beam of unpolarised light of intensity I_0 is incident on a polaroid P_1 . The light transmitted by it is then incident on a second polaroid P_2 with its pass axis making angle of 60° relative to the pass axis of P_1 . Find the intensity of the light transmitted by P_2 . [5]

OR

(a) Explain two features to distinguish between the interference pattern in Young's double slit experiment with the diffraction pattern obtained due to a single slit.

(b) A monochromatic light of wavelength 500 nm is incident normally on a single slit of width 0.2 mm to produce a diffraction pattern. Find the angular width of the central maximum obtained on the screen.

Estimate the number of fringes obtained in Young's double slit experiment with fringe

width 0.5 mm, which can be accommodated with the region of total angular spread of the central maximum due to single slit. [5]

Answer : (a) Unpolarised light : If the electric component of light vibrates in all the direction in the plane perpendicular to the direction of propagation, the light is known as unpolarised light.

Linearly polarised light: If the vibration of electric components of light are restricted in one direction only in the plane perpendicular to the propagation of light then light is known as linearly polarised light.

A polaroid consists of long chain molecules aligned in a particular direction. The electric vectors along the direction of the aligned molecules get absorbed. So, when an unpolarised light falls on a polaroid, it lets only those of its electric vectors that are oscillating along a direction perpendicular to its aligned molecules to pass through it. The incident light thus gets linearly polarised.

(b)

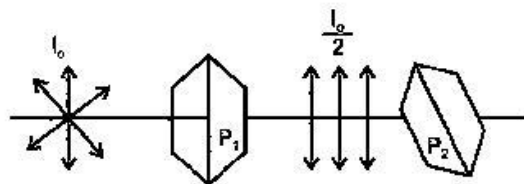

Intensity of light after passing through the polaroid

$$P_1 (I) = \frac{I_0}{2}$$

Intensity of light after passing through the polaroid

P_2

According to Malus law $I = I_0 \cos^2 \theta$

$$I = I \cos^2 60^\circ \quad [\because \theta = 60^\circ]$$

$$I = \frac{I_0}{2} \left(\frac{1}{2} \right)^2$$

$$I = \frac{I_0}{2} \times \frac{1}{4}$$

$$I = \frac{I_0}{8}$$

OR

(a)

Interference	Diffraction
1. All bright and dark fringes are of equal width.	The width of central bright fringe is twice the width of any secondary maxima.
2. All the bright fringes are of same intensity.	Intensity of bright fringes decreases as we move away from central bright fringe.

$$\begin{aligned} \text{(b) Angular width of central maxima, } \omega &= \frac{2\lambda}{a} \\ &= \frac{2 \times 500 \times 10^{-9}}{0.2 \times 10^{-3}} \\ &= 5 \times 10^{-3} \text{ rad.} \end{aligned}$$

Now, fringe width,

$$\beta = \frac{\lambda D}{d}$$

Linear width of central maxima in the diffraction pattern 0.02

$$w' = \frac{2\lambda D}{a}$$

Let 'n' be the number of interference fringes which can be accommodated in the central maxima.

$$n \times \beta = w'$$

$$n = \frac{2\lambda D}{a} \times \frac{d}{\lambda D}$$

$$n = \frac{2d}{a}$$

26. (a) Derive an expression for drift velocity of electrons in a conductor. Hence deduce Ohm's law.

(b) A wire whose cross-sectional area is increasing linearly from its one end to the other, is connected across a battery of V volts. Which of the following quantities remain constant in the wire ?

- (i) drift speed (ii) current density
(iii) electric current (iv) electric field

Justify your answer. [5]

OR

(a) State the two Kirchhoff's laws. Explain briefly how these rules are justified.

(b) The current is drawn from a cell of emf E and internal resistance r connected to the network of resistors each of resistance r as shown in the figure. Obtain the expression for (i) the current drawn from the cell and (ii) the power consumed in the network.

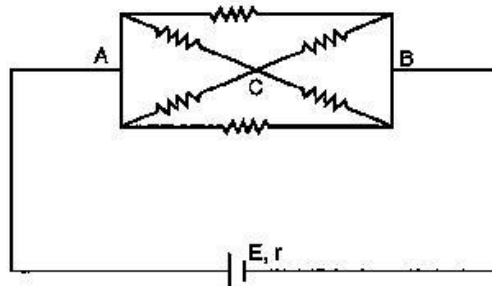

Answer : (a) Expression of Drift velocity : It is defined as the average velocity gained by the free electrons of a conductor in the opposite direction of the externally applied electric field.

If an electron have initial velocity u_1 and accelerated for time τ_1 then velocity attain by it will be

$$\vec{v}_1 = \vec{u}_1 + \vec{a}\tau_1$$

Similarly

$$\vec{v}_2 = \vec{u}_2 + \vec{a}\tau_2$$

$$\vec{v}_3 = \vec{u}_3 + \vec{a}\tau_3$$

$$\vec{v}_n = \vec{u}_n + \vec{a}\tau_n$$

Then average velocity,

$$\vec{v}_d = \frac{\vec{v}_1 + \vec{v}_2 + \vec{v}_3 + \dots + \vec{v}_n}{n}$$

$$\vec{v}_d = \frac{(\vec{u}_1 + \vec{a}\tau_1) + (\vec{u}_2 + \vec{a}\tau_2) + \dots + (\vec{u}_n + \vec{a}\tau_n)}{n}$$

$$\vec{v}_d = \frac{(\vec{u}_1 + \vec{u}_2 + \dots + \vec{u}_n)}{n} + \frac{(\tau_1 + \tau_2 + \dots + \tau_n)}{n} \vec{a}$$

$$\vec{v}_d = 0 + \vec{a}\tau$$

$$\vec{v}_d = \vec{a}\tau$$

where $\tau = \frac{\tau_1 + \tau_2 + \dots + \tau_n}{n}$ = average relaxation time.

$$\vec{v}_d = \frac{-e\vec{E}\tau}{m} \quad \left[\because a = \frac{-e\vec{E}}{m} \right]$$

$$|\vec{v}_d| = \left| \frac{-e\vec{E}\tau}{m} \right|$$

Now,

$$v_d = \frac{eE\tau}{m}$$

$$v_d = \frac{eV\tau}{ml} \quad \left[\because E = \frac{V}{l} \right]$$

Now charge flowing through conductor at an instant is

and $I = neAv_d$

$$I = neA \frac{eV\tau}{ml}$$

$$\frac{V}{I} = \frac{ml}{ne^2\tau A}$$

If physical condition remain unchanged then right hand side will be constant.

$$\therefore \frac{V}{I} = \text{Constant}$$

$$\frac{V}{I} = R \text{ or } V = IR$$

Hence, Ohm's law is derived.

(b) The electric current will remain constant in the wire as it does not depend upon the cross-sectional area whereas the drift speed, current density, electric field depends upon the increasing area of cross-section with the following relations:

$$\text{Drift speed, } v_d = \frac{I}{neA}$$

$$\text{Current density, } J = \frac{I}{A}$$

$$\text{Electric field, } E = \frac{J}{\sigma}$$

OR

(a) Kirchhoff's laws :

1. Kirchhoff's first law or junction rule : In an electric circuit, the algebraic sum of currents at any junction is zero.

$$\sum I = 0$$

2. Kirchhoff's second law or loop rule : Around any closed loop of a network, the algebraic sum of changes in the potential must be zero.

$$\sum \Delta V = 0$$

Justification : First law is based on the law of conservation of charge and second law is based on the law of conservation of energy.

(b) 1.

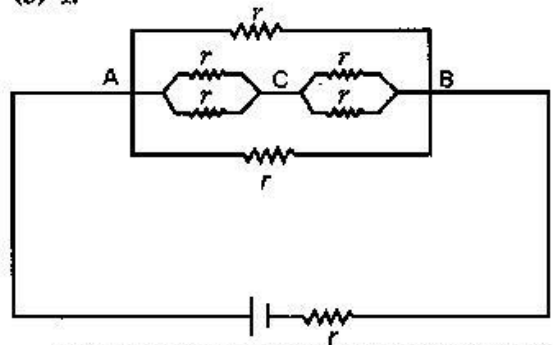

The equivalent resistance between AC and CB is given by

$$\frac{1}{r'} = \frac{1}{r} + \frac{1}{r}$$

$$\frac{1}{r'} = \frac{2}{r}$$

$$r' = \frac{r}{2}$$

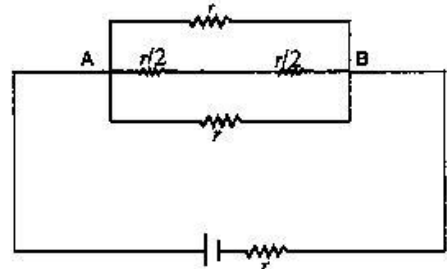

The equivalent resistance of middle branch is given by,

$$r'' = \frac{r}{2} + \frac{r}{2} = r$$

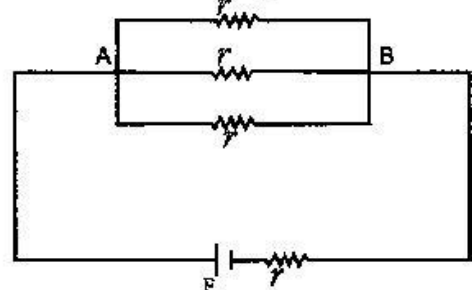

The equivalent resistance between A and B is

given by

$$\frac{1}{r'''} = \frac{1}{r} + \frac{1}{r} + \frac{1}{r}$$

$$r''' = \frac{r}{3}$$

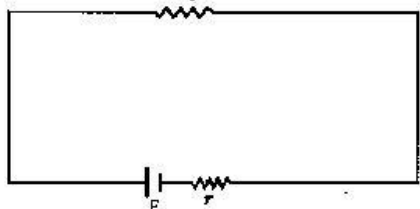

Total resistance of the circuit is given by,

$$R = \frac{r}{3} + r$$

$$R = \frac{4r}{3}$$

Now current through the circuit is given by

$$I = \frac{E}{\frac{4r}{3}}$$

$$I = \frac{3E}{4r}$$

2. Power consumption = PI

$$= \left(\frac{3E}{4r}\right)^2 \frac{4r}{3}$$

$$P = \frac{3E^2}{4r}$$

••

Physics 2017 (Delhi)

SET II

Time allowed : 3 hours

Note : Except for the following questions, all the remaining questions have been asked in previous set.

6. Find the wavelength of the electron orbiting in the first excited state in hydrogen atom. [2]

Answer : Radius of n^{th} orbit,

$$r_n = r_0 n^2 = 0.53 n^2 \text{ \AA}$$

For 1st excited state $n = 2$.

$$\therefore r_2 = 0.53 \times 4 \text{ \AA}$$

$$= 2.12 \text{ \AA}$$

For an electron revolving in n^{th} orbit, according to de Broglie relation,

$$2\pi r_n = n\lambda$$

$$2 \times 3.14 \times 2.12 \times 10^{-10} = 2\lambda$$

$$\lambda = 3.14 \times 2.12 \times 10^{-10} \text{ m}$$

$$= 6.67 \text{ \AA}$$

7. Distinguish between a transducer and a repeater.** [2]

10. Why should the objective of a telescope have large focal length and large aperture ? Justify your answer. [2]

Answer : Magnifying power of telescope, $m = -\frac{f_o}{f_e}$

$\therefore f_o$ should be large.

$$\text{Also, R.P. of telescope} = \frac{A}{1.22 \lambda}$$

\therefore Aperture should also be large to increase resolving power.

Maximum marks : 70

12. In the study of a photoelectric effect the graph between the stopping potential V and frequency ν of the incident radiation on two different metals P and Q is shown below: [3]

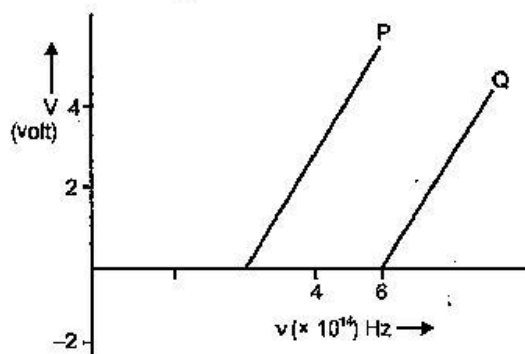

(i) Which one of the two metals has higher threshold frequency ?

(ii) Determine the work function of the metal which has greater value.

(iii) Find the maximum kinetic energy of electron emitted by light of frequency $8 \times 10^{14} \text{ Hz}$ for this metal.

Answer : (i) Q has higher threshold frequency.

(ii) Work function of Q

$$\phi_0 = h\nu_0$$

$$h\nu_0 = (6.6 \times 10^{-34}) \times \frac{6 \times 10^{14}}{1.6 \times 10^{-19}} \text{ eV}$$

$$= 2.5 \text{ eV}$$

(iii) $K_{\text{max}} = h(\nu - \nu_0)$

$$= \frac{6.6 \times 10^{-34} (8 \times 10^{14} - 6 \times 10^{14})}{1.6 \times 10^{-19}} \text{ eV}$$

$$= \frac{6.6 \times 10^{-34} \times 2 \times 10^{14}}{1.6 \times 10^{-19}} \text{ eV}$$

$$K_{\max} = 0.83 \text{ eV}$$

13. A 12 pF capacitor is connected to a 50 V battery. How much electrostatic energy is stored in the capacitor? If another capacitor of 6 pF is connected in series with it with the same battery connected across the combination, find the charge stored and potential difference across each capacitor. [3]

Answer : Energy stored in the capacitor of capacitance 12 pF,

$$\begin{aligned} U &= \frac{1}{2} CV^2 \\ &= \frac{1}{2} \times 12 \times 10^{-12} \times 50 \times 50 \text{ J} \\ &= 1.5 \times 10^{-8} \text{ J} \end{aligned}$$

Let C be the equivalent capacitance of 12 pF and 6 pF capacitor connected in series and it is given by

$$\frac{1}{C} = \frac{1}{12} + \frac{1}{6} = \frac{1+2}{12}$$

$$\therefore C = 4 \text{ pF}$$

As the capacitors are connected in series, so the charge remains same

$$\begin{aligned} \therefore \text{Charge stored across each capacitor,} \\ q &= CV = 4 \times 10^{-12} \times 50 \\ &= 2 \times 10^{-10} \text{ C} \end{aligned}$$

Potential difference across capacitor C_1 ,

$$V_1 = \frac{2 \times 10^{-10}}{12 \times 10^{-12}} \text{ volt} = \frac{50}{3} \text{ V}$$

Potential difference across capacitor C_2 ,

$$V_2 = \frac{2 \times 10^{-10}}{6 \times 10^{-12}} \text{ volt} = \frac{100}{3} \text{ V}$$

18. A zener diode is fabricated by heavily doping both p and n- sides of the junction. Explain, why? Briefly explain the use of zener diode as a dc voltage regulator with the help of a circuit diagram. [3]

Answer : By heavily doping both p and n sides of the junction, depletion region formed is very thin, i.e. $< 10^{-6} \text{ m}$. Hence, electric field across the junction is very high ($\sim 5 \times 10^6 \text{ V/m}$) even for a small reverse bias voltage. This can lead to a breakdown during reverse biasing.

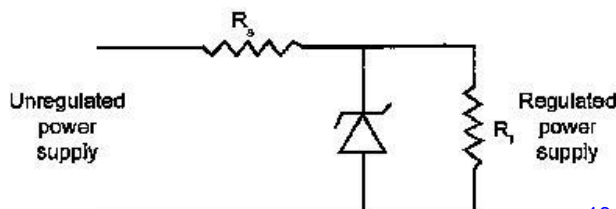

If the input voltage increases/decreases then current through resistor R_s and Zener diode also increases/decreases. This increases/decreases the voltage drop across R_s without any change in voltage across the zener diode.

This is because in the breakdown region, zener voltage remains constant even though the current through the zener diode changes.

21. A electron of mass m_e revolves around a nucleus of charge $+Ze$. Show that it behaves like a tiny magnetic dipole. Hence prove that the magnetic moment associated with it is expressed as

$\vec{\mu} = -\frac{e}{2m_e} \vec{L}$, where \vec{L} is the orbital angular momentum of the electron. Give the significance of negative sign. [3]

Answer : Electron in circular motion around the nucleus, constitutes a current loop which behaves like a magnetic dipole.

Current associated with the revolving electron,

$$I = \frac{e}{T}$$

and

$$T = \frac{2\pi r}{v}$$

\therefore

$$I = \frac{e}{2\pi r} v$$

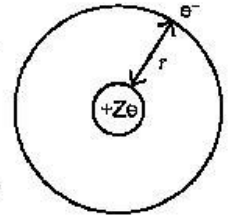

Magnetic moment of the loop,

$$\mu = IA$$

$$\mu = IA = \frac{ev}{2\pi r} \pi r^2$$

$$= \frac{evr}{2} = \frac{e \cdot m_e v r}{2m_e} \quad (i)$$

Orbital angular momentum of the electron,

$$L = m_e v r$$

Put the value of L in equation (i) (ii)

$$\vec{\mu} = \frac{-e}{2m_e} \vec{L}$$

The negative sign signifies that the angular momentum of the revolving electron is opposite in direction to the magnetic moment associated with it.

22. (a) Derive the expression for the electric potential due to an electric dipole at a point on its axial line. (b) Depict the equipotential surfaces due to an electric dipole. [3]

Answer : (a) Consider an electric dipole having charges $-q$ and $+q$ at separation $'2a'$. The dipole moment of dipole is $\vec{p} = q(2\vec{a})$, directed from $-q$ to $+q$.

The electric potential due to dipole is the algebraic sum of potentials due to charges $+q$ and $-q$.

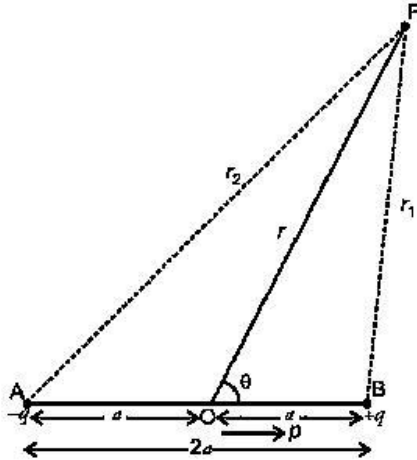

If r_1 and r_2 are distances of any point P from charge $+q$ and $-q$ respectively as shown in the figure, then the potential due to electric dipole at point P, is

$$V = \frac{1}{4\pi\epsilon_0} \frac{q}{r_1} - \frac{1}{4\pi\epsilon_0} \frac{q}{r_2}$$

$$= \frac{q}{4\pi\epsilon_0} \left[\frac{1}{r_1} - \frac{1}{r_2} \right] \quad \dots(i)$$

If (r, θ) are polar coordinates of point P with respect to mid-point O of dipole, then

By geometry,

$$r_1^2 = r^2 + a^2 - 2ar \cos \theta \quad \dots(ii)$$

and $r_2^2 = r^2 + a^2 + 2ar \cos \theta \quad \dots(iii)$

From (ii), $r_1^2 = r^2 \left[1 - \frac{2a \cos \theta}{r} + \frac{a^2}{r^2} \right]$

If $r \gg a$ i.e., $\frac{a}{r} \ll 1$, then it is sufficient to retain terms only upto first order in $\left(\frac{a}{r}\right)$.

$$\therefore r_1^2 = r^2 \left[1 - \frac{2a \cos \theta}{r} \right]$$

$$\Rightarrow r_1 = r \left[1 - \frac{2a \cos \theta}{r} \right]^{1/2} \quad \dots(iv)$$

Similarly from (iii),

$$r_2^2 = r^2 \left[1 + \frac{2a \cos \theta}{r} \right]$$

$$\Rightarrow r_2 = r \left[1 + \frac{2a \cos \theta}{r} \right]^{1/2} \quad \dots(v)$$

From (iv) and (v),

$$\frac{1}{r_1} = \frac{1}{r} \left[1 - \frac{2a \cos \theta}{r} \right]^{-1/2}$$

$$\text{and } \frac{1}{r_2} = \frac{1}{r} \left[1 + \frac{2a \cos \theta}{r} \right]^{-1/2}$$

Using binomial theorem and retaining terms upto first order in $\frac{a}{r}$ only, we have

$$\frac{1}{r_1} = \frac{1}{r} \left[1 - \left(-\frac{1}{2} \right) \frac{2a \cos \theta}{r} \right]$$

$$= \frac{1}{r} \left[1 + \frac{a}{r} \cos \theta \right] \quad \dots(vi)$$

$$\text{and } \frac{1}{r_2} = \frac{1}{r} \left[1 - \frac{a}{r} \cos \theta \right] \quad \dots(vii)$$

Substituting these values in (i), we get

$$V = \frac{q}{4\pi\epsilon_0} \left[\frac{1}{r} \left(1 + \frac{a}{r} \cos \theta \right) - \frac{1}{r} \left(1 - \frac{a}{r} \cos \theta \right) \right]$$

$$= \frac{1}{4\pi\epsilon_0} \frac{q}{r} \left[1 + \frac{a}{r} \cos \theta - 1 + \frac{a}{r} \cos \theta \right]$$

$$= \frac{1}{4\pi\epsilon_0} \frac{q}{r} \left[\frac{2a}{r} \cos \theta \right]$$

$$= \frac{1}{4\pi\epsilon_0} \frac{(q \cdot 2a) \cos \theta}{r^2}$$

$$\text{or } V = \frac{1}{4\pi\epsilon_0} \frac{p \cos \theta}{r^2} \quad \dots(viii)$$

When point P lies on the axis of dipole, then $\theta = 0^\circ$

$$\therefore \cos \theta = \cos 0^\circ = 1$$

$$\therefore V = \frac{1}{4\pi\epsilon_0} \cdot \frac{p}{r^2}$$

(b)

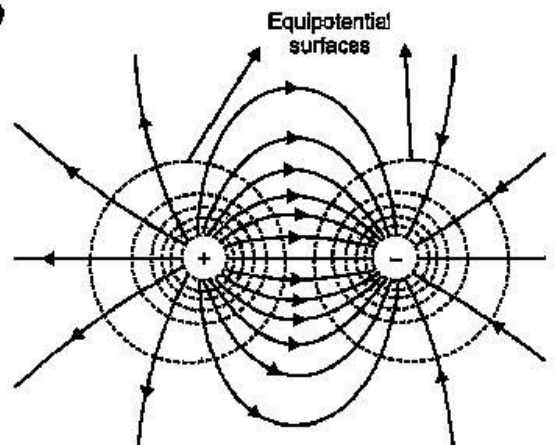

Equipotential surfaces get closer to each other near the point charges, as strong electric field is produced there.

Time allowed : 3 hours

Maximum marks : 70

Note : Except for the following questions, all the remaining questions have been asked in previous sets.

7. When are two objects just resolved ? Explain. How can the resolving power of a compound microscope be increased ? Use relevant formula to support your answer. [2]

Answer : When the maxima of diffraction pattern from one object coincide with the minima of second object then they are just resolved.

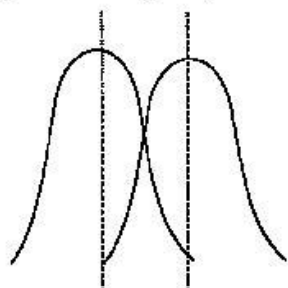

$$R.P. = \frac{2\mu \sin\theta}{\lambda}$$

The resolving power of a compound microscope can be increased by increasing μ and by decreasing λ .

8. (a) What is the line of sight communication ?**
 (b) Why is it not possible to use sky waves for transmission of T.V. signals ? Upto what distance can a signal be transmitted using an antenna of height 'h' ?** [2]
9. An α -particle and a proton are accelerated through the same potential difference. Find the ratio of their de Broglie wavelengths. [2]

Answer : de Broglie wavelength,

$$\lambda = \frac{h}{P} = \frac{h}{\sqrt{2mK}} = \frac{h}{\sqrt{2mqV}}$$

$$\therefore \frac{\lambda_\alpha}{\lambda_p} = \frac{\sqrt{m_p q_p}}{\sqrt{m_\alpha q_\alpha}} = \frac{\sqrt{m_e}}{\sqrt{4m_p \cdot 2e}} \quad \left[\begin{array}{l} \because m_\alpha = 4m_p \\ q_\alpha = 2q_p \end{array} \right]$$

$$\frac{\lambda_\alpha}{\lambda_p} = \sqrt{\frac{1}{8}} = \frac{1}{2\sqrt{2}}$$

$$\therefore \lambda_\alpha : \lambda_p = 1 : 2\sqrt{2}$$

14. (a) State two important features of Einstein's photoelectric equation.

(b) Radiation of frequency 10^{15} Hz is incident on two photosensitive surfaces P and Q.

There is no photoemission from surface P. Photoemission occurs from surface Q but photoelectrons have zero kinetic energy. Explain these observations and find the value of work function for surface Q. [3]

Answer : (a) 1. By Einstein's photoelectric equation we can explain the laws of photoelectric emission.

2. By this we can find the value of Planck's constant and work function.

(b) Given : $\nu = 10^{15}$ Hz

$$\text{Wavelength, } \lambda = \frac{c}{\nu} = \frac{3 \times 10^8}{10^{15}} = 300 \text{ nm}$$

$$\begin{aligned} \text{Energy, } E &= \frac{hc}{\lambda} = \frac{6.6 \times 10^{-34} \times 3 \times 10^8}{300 \times 10^{-9}} \\ &= \frac{6.6 \times 10^{-19}}{1.6 \times 10^{-19}} \text{ eV} \\ &= 4.125 \text{ eV} \end{aligned}$$

The work function of P is more than the 4.125 eV Therefore there is no photoemission from surface P.

For surface Q, the kinetic energy is zero,

$$\begin{aligned} \therefore K.E_{\text{max}} &= E - \phi_0 \\ 0 &= E - \phi_0 \end{aligned}$$

\Rightarrow Work function, $\phi_0 = E = 4.15 \text{ eV}$

16. (a) Obtain the expression for the torque $\vec{\tau}$ experienced by an electric dipole of dipole moment \vec{p} in a uniform electric field, \vec{E} .

(b) What will happen if the field were not uniform ? [3]

Answer : (a)

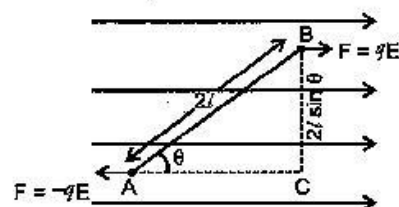

$\tau = \text{Force} \times \text{Perpendicular distance}$

$$\tau = F \times BC$$

$$\tau = qE \times 2l \sin \theta$$

$$\tau = pE \sin \theta \quad (\because p = q \times 2l)$$

$$\vec{\tau} = \vec{p} \times \vec{E}$$

(b) If the field is non-uniform then there will be a net force acting on the dipole. Also, a net torque acting on the dipole which depends on the location of the dipole.

17. Explain briefly with the help of necessary diagrams, the forward and the reverse biasing of a p-n junction diode. Also draw their characteristic curves in the two cases. [3]

Answer : Forward biasing : If the positive terminal of the battery is connected to the p type semiconductor and negative terminal to the n type semiconductor then it is said to be in forward biased.

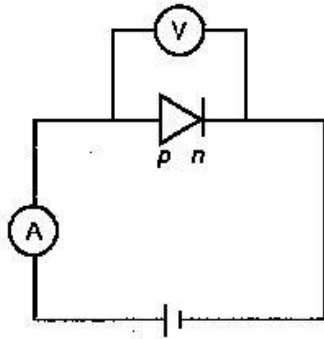

Forward biasing

Characteristics :

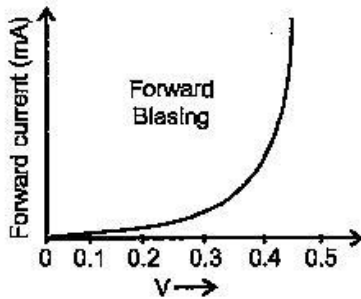

Reverse Biasing : If the positive terminal of the battery is connected to the n type semiconductor and the negative terminal to the p type semiconductor then it is said to be reverse biased.

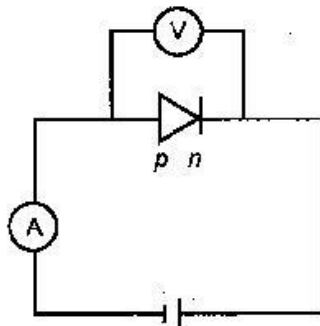

Reverse biasing

Characteristics :

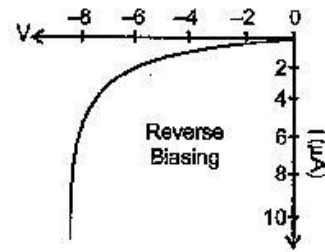

20. Two identical capacitors of 12 pF each are connected in series across a battery of 50 V. How much electrostatic energy is stored in the combination ? If these were connected in parallel across the same battery, how much energy will be stored in the combination now ? Also find the charge drawn from the battery in each case. [3]

Answer : Case I : When the capacitors are connected in series.

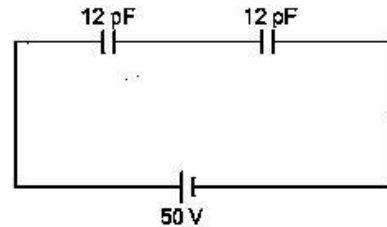

The equivalent capacitance is given by

$$C_{eq} = \frac{12 \times 12}{12 + 12} = \frac{12 \times 12}{24}$$

$$C_{eq} = 6 \text{ pF} = 6 \times 10^{-12} \text{ F}$$

Electrostatic energy,

$$U = \frac{1}{2} CV^2$$

$$= \frac{1}{2} \times 6 \times 10^{-12} \times 50 \times 50$$

$$U = 75 \times 10^{-10} \text{ J.}$$

As the capacitors are connected in series so, the charge remains the same.

$$\therefore Q = C_{eq} V$$

$$Q = 6 \times 10^{-12} \times 50$$

$$Q = 300 \text{ pF} = 300 \times 10^{-12} \text{ F}$$

Case II : When the capacitors are connected in parallel.

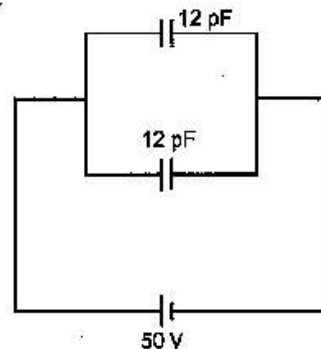

- 19 The equivalent capacitance is given by,

$$C_{eq} = (12 + 12) \text{ pF}$$

$$= 24 \text{ pF} = 20 \times 10^{-12} \text{ F}$$

Electrostatic energy,

$$U = \frac{1}{2} \times 24 \times 10^{-12} \times (50)^2$$

$$U = 3 \times 10^{-8} \text{ J}$$

As the capacitors are connected in parallel so, the charge on each capacitor is different but potential difference remains the same.

Charge on C_1 ,

$$Q_1 = C_1 V$$

$$Q_1 = 12 \times 10^{-12} \times 50$$

$$= 600 \times 10^{-12} \text{ F}$$

Similarly, $Q_2 = 600 \times 10^{-12} \text{ F}$

Total charge, $Q = Q_1 + Q_2$

$$= (600 + 600) \times 10^{-12}$$

$$= 1200 \times 10^{-12}$$

$$= 12 \times 10^{-10} \text{ F}$$

21. (a) Write the expression for the force \vec{F} acting on a particle of mass m and charge q moving with velocity \vec{v} in a magnetic field \vec{B} . Under what conditions will it move in (i) a circular path and (ii) a helical path?

(b) Show that the kinetic energy of the particle moving in magnetic field remains constant.

[3]

Answer : (a) $\vec{F} = q(\vec{v} \times \vec{B}) = qvB \sin \theta$

(i) If the angle between v and B is 90° then it will move in circular path.

(ii) If the angle is other than, 0° , 90° and 180° the path will be helical.

(b) Since the work done on the charged particle moving in the magnetic field is zero because force experienced is perpendicular cannot bring any change in speed of charged particuler. Hence the change in K.E. is zero.

••

