

# Physics 2016 (Outside Delhi)

SET I

Time allowed : 3 hours

Maximum marks : 70

## SECTION — A

1. A charge ' $q$ ' is moved from a point A above a dipole of dipole moment ' $p$ ' to a point B below the dipole in equatorial plane without acceleration. Find the work done in the process. [1]

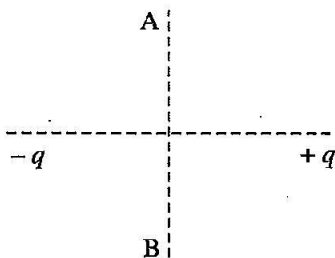

**Answer :** Work done,  $W = q(V_B - V_A) = q \times 0 = 0$

2. In what way is the behaviour of a diamagnetic material different from that of a paramagnetic, when kept in an external magnetic field? [1]  
**Answer :** The magnetic field lines pass through the paramagnetic material while the magnetic field lines move away from the diamagnetic material. or paramagnetic material get aligned along B and diamagnetic aligned perpendicular to B.
3. Name the essential components of a communication system. [1]  
**Answer :** The essential components are :  
 Transmitter, communication channel and receiver.

4. Why does sun appear red at sunrise and sunset? [1]

**Answer :** Sun appears red at sunrise and sunset due to the least scattering of red light as it has the longest wavelength.

5. The plot of the variation of potential difference across a combination of three identical cells in series, versus current is shown below. What is the emf and internal resistance of each cell? [1]

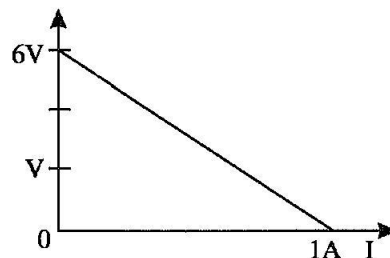

**Answer :**  
 We know that,

$$V = E - Ir$$

Where  $E$  is the e.m.f. and  $r$  is the total internal resistance.

When  $I = 0$ ,

$$\text{Total emf} = \text{Terminal voltage}$$

$$3E = 6V$$

emf. of each cell  $E = 2V$

When  $V = 0$   
 $E = Ir$

$$r = \frac{\text{Total E.m.f}}{I} = \frac{6}{1} = 6\Omega$$

As the cells are connected in series. So, the internal resistance of each cell =  $2\Omega$ .

### SECTION—B

6. Define modulation index. Why is it kept low? What is the role of a bandpass filter? \*\* [2]
7. A ray PQ incident normally on the refracting face BA is refracted in the prism BAC made of material of refractive index 1.5. Complete the path of ray through the prism. From which face will the ray emerge? Justify your answer. [2]

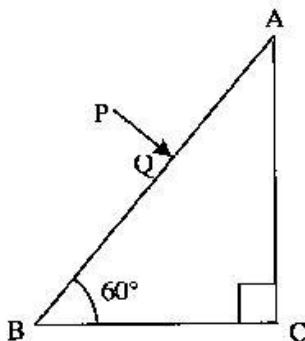

Answer :

We know that,

$$n = \frac{1}{\sin C}$$

Where,

$n$  = Refractive index

$C$  = Critical angle.

So,

$$\sin C = 1/n = 1/1.5 = 0.667$$

$$\sin C = \sin 41^\circ 49'$$

$$C = 41^\circ 49'$$

$$C > 30^\circ$$

Angle on face AC, which is greater than incident

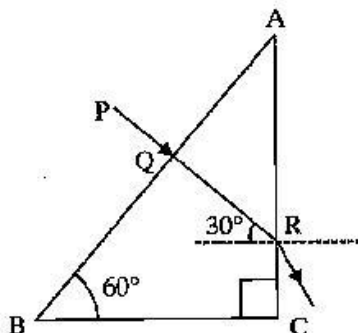

Thus, the light ray PQ will emerge out from face AC.

8. Calculate the de-Broglie wavelength of the electron orbiting in the  $n = 2$  stage of hydrogen atom. [2]

Answer : The velocity of an orbiting electron,

$$v = \frac{Zc}{137n}$$

Where,  $c$  = Speed of light in vacuum.

$$\text{So, } v = \frac{1 \times 3 \times 10^8}{137 \times 2} = 1.09 \times 10^6 \text{ m/s.}$$

The de-Broglie wavelength,  $\lambda = h/mv$

Where  $h$  is Planck's constant =  $6.6 \times 10^{-34}$  Js

and mass of electron =  $9.1 \times 10^{-31}$  kg

$$\text{So, } \lambda = \frac{6.6 \times 10^{-34}}{(9.1 \times 10^{-31} \times 1.09 \times 10^6)} = 6.65 \times 10^{-9} \text{ m}^{-9}$$

9. Define ionization energy.

How would the ionization energy change when electron in hydrogen atom replaced by a particle of mass 200 times that of the electron but having the same charge? [2]

OR

Calculate the shortest wavelength of the spectral lines emitted in Balmer series. [Given Rydberg constant,  $R = 10^7 \text{ m}^{-1}$ ]

Answer : Ionization energy is defined as the amount of energy needed to remove the valence electron of an isolated gaseous atom.

The ionization energy of hydrogen atom is

$$E_H \propto m_e \dots(i)$$

When mass of electron is replaced by a particle having mass =  $200 m_e$ , then

$$E'_H \propto 200 m_e \dots(ii)$$

From (i) and (ii), we have

$$E'_H = 200 E_H = 200 \times (-13.6) = -2720 \text{ eV} \quad (\because E_H = -13.6 \text{ eV})$$

OR

For Balmer series, wavelength is given by :

$$\frac{1}{\lambda} = R \left[ \frac{1}{2^2} - \frac{1}{n^2} \right]$$

Where,  $n = 3, 4, 5$

For shortest wavelength,  $n = \infty$

$$\text{So, } \frac{1}{\lambda} = R \left[ \frac{1}{2^2} - \frac{1}{\infty^2} \right]$$

$$\frac{1}{\lambda} = 10^7 \left[ \frac{1}{4} \right]$$

$$\lambda = 4 \times 10^{-7} \text{ m.}$$

10. A battery of emf 12 V and internal resistance  $2\Omega$  is connected to a  $4\Omega$  resistor as shown in the figure. [2]

(a) Show that a voltmeter when placed across the cell and across the resistor, in turn, gives the same reading.

(b) To record the voltage and the current in the circuit, why is voltmeter placed in parallel and ammeter in series in the circuit?

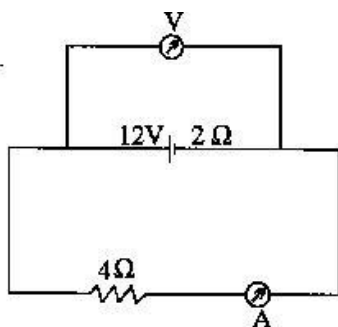

**Answer :** We know that,

(a) Effective resistance of the circuit  $R_E = 6 \Omega$

$$\therefore I = \frac{12}{6} = 2A$$

Terminal potential difference across the cell can be calculated as,

$$V = E - Ir = 12 - 2 \times 2 = 12 - 4 = 8V$$

Also, Potential difference across  $4\Omega$  resistor can be calculated as

$$V = IR = 2 \times 4 = 8V.$$

So, a voltmeter when placed across the cell and across the resistor, gives the same reading.

(b) An ammeter is connected in series because it has very low resistance. So, when, an ammeter is connected in series, then there is not much increase in the resistance of the circuit and hence the current through the circuit unchanged.

A voltmeter is connected in parallel because it has very high resistance. So, it draws a very small current from the circuit.

### SECTION—C

11. Define an equipotential surface. Draw equipotential surfaces : [3]

- (i) in the case of a single point charge and
- (ii) in a constant electric field in Z-direction.

Why the equipotential surfaces about a single charge are not equidistant ?

(iii) Can electric field exist tangential to an equipotential surface ? Give reason.

**Answer :** An equipotential surface is the surface which has same potential at its every point.

(i)

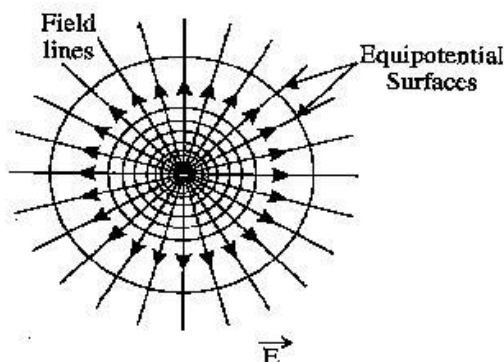

(ii)

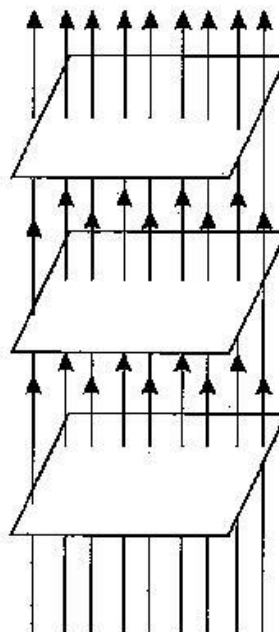

The electric field due to single charge is not constant, this is the reason why the equipotential surfaces about a single charge are not equidistant and potential vary

inversely with radius i.e.,  $V \propto \frac{1}{r}$

(iii) No, electric field cannot exist tangential to an equipotential surface. If it happen then a charged particle will experience a force along the tangential line and can move along it. As a charged particle can move only due to the potential difference i.e., along the direction of charge of potential, this contradicts the concept of an equipotential surface.

12. (i) State law of Malus.

(ii) Draw a graph showing the variation of intensity (I) of polarised light transmitted by an analyser with angle ( $\theta$ ) between polariser and analyser.

(iii) What is the value of refractive index of a medium of polarising angle  $60^\circ$ ? [3]

**Answer :** (i) Malus discovered that when a beam of completely plane polarized light is passed through the analyser, the intensity 'I' of transmitted light changes directly as the square of the cosine of the angle  $\theta$  between the transmission directions of polarizer and analyzer.

This is known as the law of Malus.

$$I \propto \cos^2 \theta$$

or 
$$I = I_0 \cos^2 \theta$$

Where,  $I_0$  is the maximum intensity of the transmitted light.

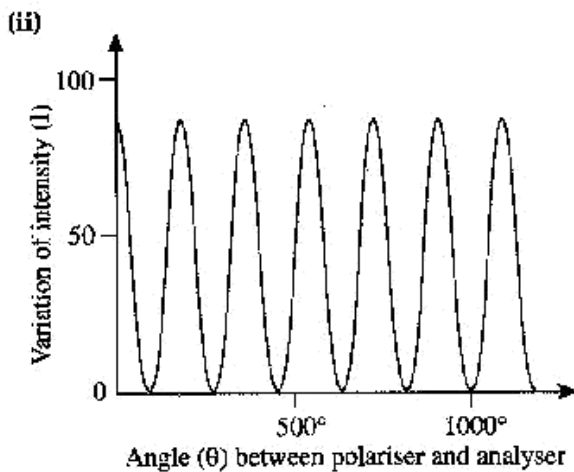

(iii) From the Brewster's law of polarization :

$$\begin{aligned} \mu &= \tan i_p \\ &= \tan 60^\circ \\ &= \sqrt{3} \\ &= 1.7320 \end{aligned}$$

Thus, the refractive index of the material is 1.73.

13. Sketch the graphs showing variation of stopping potential with frequency of incident radiations for two photosensitive materials A and B having threshold frequencies  $\nu_A > \nu_B$ . [3]

(i) In which case is the stopping potential more and why?

(ii) Does the slope of the graph depend on the nature of the material used? Explain.

Answer :

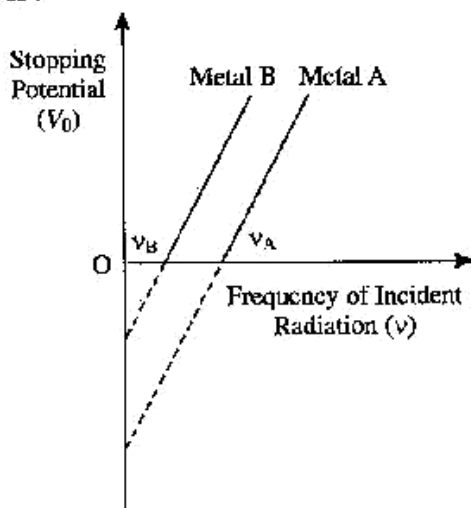

(i) We know that,

$$V_0 = \frac{h}{e} (\nu - \nu_0)$$

For the same value of  $\nu$ , stopping potential is more for which threshold frequency ( $\nu_0$ ) is less.

Given,  $\nu_A > \nu_B$

Therefore, threshold frequency for metal B is less than the threshold frequency for metal A.

Hence, stopping potential is more for metal B.

(ii) No, the slope of the graph tells us the value of  $h/e$  which is same for both the materials. So, it does not depend on the nature of the materials.

14. (a) Write the basic nuclear process involved in the emission of  $\beta^-$  in a symbolic form, by a radioactive nucleus.

(b) In the reactions given below :

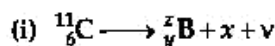

Find the value of  $x, y, z$  and  $a, b, c$ . [3]

Answer : (a) In  $\beta^-$ -decay, the atomic number of the radioactive nucleus decreases by one and its mass number remains same. In this process, a positron ( $e^+$ ) and a new particle neutrino ( $\nu$ ) are emitted from the nucleus.

Generally,  ${}_{Z}^AX \rightarrow {}_{Z-1}^AY + e^+ + \nu$

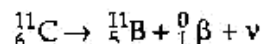
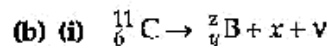

The corresponding  $y$  and  $z$  are 5 and 11, respectively. The  $x$  is the positron.

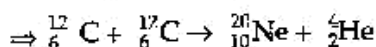
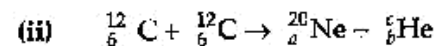

The corresponding values of  $a, b, c$  are 10, 2 and 4, respectively.

15. (i) Derive an expression for drift velocity of free electrons.

(ii) How does drift velocity of electrons in a metallic conductor vary with increase in temperature? Explain. [3]

Answer : (i) Consider a conductor in which an electric field  $E$  is produced. Let a free electron experience a force ( $-eE$ ) in this electric field. So, the acceleration of free electron is

$$a = F/m = -eE/m \quad \dots(i)$$

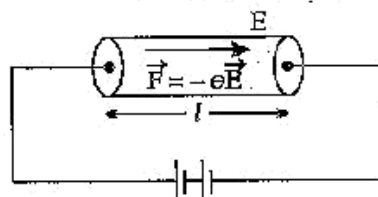

Here,  $e$  = Charge on electron.

$m$  = Mass of an electron.

So, the final velocity of the free electron in time interval  $t_1$  is,

$$v_1 = u_1 + at_1$$

For  $n$  free electrons, the final velocities be  $v_2, v_3, \dots, v_n$ .

So, the average velocity of the free electrons or the drift velocity

$$v_d = \frac{(v_1 + v_2 + v_3 + \dots + v_n)}{n}$$

or 
$$v_d = \frac{(u_1 + at_1 + u_2 + at_2 + \dots + u_n + at_n)}{n}$$

or 
$$v_d = \frac{[(u_1 + u_2 + \dots + u_n) + (at_1 + at_2 + \dots + at_n)]}{n}$$

or 
$$v_d = \frac{[(u_1 + u_2 + \dots + u_n) + a(t_1 + t_2 + \dots + t_n)]}{n}$$

But,  $\frac{(u_1 + u_2 + \dots + u_n)}{n}$  = average initial velocity of free electrons = 0.

and  $\frac{(t_1 + t_2 + \dots + t_n)}{n}$  = average time taken between two consecutive collision =  $\tau$

where  $\tau$  is relaxation time.

So, 
$$v_d = a\tau$$

or, 
$$v_d = \frac{-eE}{m} \tau$$
 [ from (i) ]

This is the required relation.

(ii) The drift velocity of free electrons in a metallic conductor decreases with increase in temperature. because, if we increase the temperature of the metallic conductor the collision between the electrons and ions increases, which decreases relaxation time. Hence, drift velocity decreases.

16. (i) When an AC source is connected to an ideal inductor show that the average power supplied by the source over a complete cycle is zero.

(ii) A lamp is connected in series with an inductor and an AC source. What happens to the brightness of the lamp when the key is plugged in and an iron rod is inserted inside the inductor? Explain. [3]

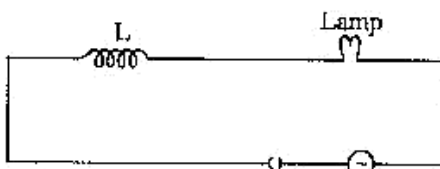

**Answer :** (i) The average power supplied by the source over a complete cycle is

$$P_{av} = E_{rms} I_{rms} \cos \phi$$

When the circuit contains an ideal inductor, then the phase difference between the current and voltage is  $\pi/2$ .

So,  $\phi = \pi/2$ . So,  $\cos \phi = \cos \pi/2 = 0$ .

Hence  $P_{av} = 0$ .

So, when an ac source is connected to an ideal inductor, the average power supplied by the source over a complete cycle is zero.

(ii) The brightness of the lamp will decrease. When the key is plugged in and the iron rod is inserted inside the inductor, it increases the inductance. Hence, the reactance of the inductor ( $X_L = \omega L$ ) increases. So, the impedance of the circuit ( $Z = R + j\omega L$ ) increases, which decreases the current in the circuit.

17. (i) Explain with the help of a diagram the formation of depletion region and barrier potential in a  $p-n$  junction.

(ii) Draw the circuit diagram of a half wave rectifier and explain its working. [3]

**Answer :** (i) During the formation of  $p-n$  junction, the holes diffuse from  $p$ -type semiconductor to the  $n$ -type, and electrons diffuse from  $n$ -type to  $p$ -type. This is because of the concentration gradient across  $p$ -side and  $n$ -side.

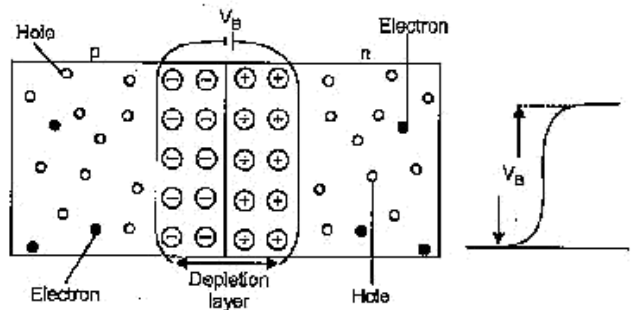

When a hole diffuses from  $p$  to  $n$  type, it leaves an unmovable negative charge. Similarly, when an electron diffuses from  $n$  to  $p$  type, it leaves an unmovable positive charge. When the diffusion of holes and electrons takes place continuously across the junction, a layer of unmovable positive and negative charges are developed on either side of the junction. This layer is called the depletion layer or the depletion region and the potential difference across the region is called barrier potential.

(ii) Half wave rectifier :

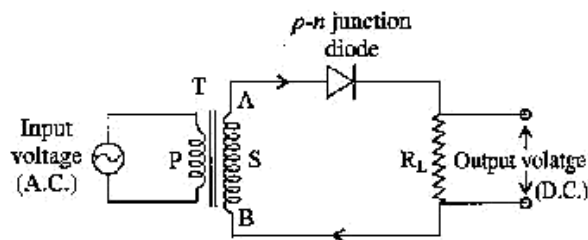

**Working :** When an input ac voltage is applied across the primary coil, a potential difference is developed across the ends of the secondary coil. Consider that in half cycle of input ac signal, the end A acts as the +ve end and B acts as the -ve end of the battery. So, the diode is in forward bias and we get output across the ends of the load resistance  $R_L$ .

In the second half cycle, ends A and B reverse in polarity. Now, A acts as the -ve end and B acts as the +ve end. So, the diode D is in reverse bias and no output is obtained due to the high resistance offered by the diode.

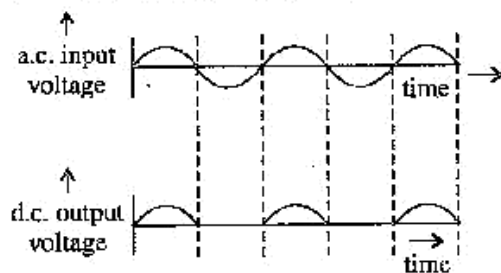

So, in this process, we get output alternately, and hence the diode is called the half wave rectifier.

18. (i) Which mode of propagation is used by short wave broadcast service having frequency range from a few MHz upto 30 MHz ? Explain diagrammatically how long distance communication can be achieved, by this mode.\*\*
- (ii) Why is there an upper limit to frequency of waves used in this mode ?\*\* [3]
19. (i) Identify the part of the electromagnetic spectrum which is :
- (a) suitable for radar system used in aircraft navigation,
  - (b) produced by bombarding a metal target by high speed electron.
- (ii) Why does a galvanometer show a momentary deflection at the time of charging or discharging a capacitor ? Write the necessary expression to explain this observation. [3]

**Answer :** (i) (a) Microwaves, (b) X-rays

(ii) During the charging and discharging of a capacitor, a flow of charges take place from the battery to the plates of the capacitor. This produces a conduction current in the circuit and a displacement current between plates. Hence the galvanometer shows a momentary deflection.

$$\oint B \cdot dl = \mu_0 I + I_d$$

Where

$$I_d = \frac{\epsilon_0 d \phi_E}{dt}$$

20. For a CE-transistor amplifier, the audio signal voltage across the collector resistance of  $2 \text{ k}\Omega$  is  $2 \text{ V}$ . Suppose the current amplification factor of the transistor is 100, find the input signal voltage and base current, if the base resistance is  $1 \text{ k}\Omega$ .\*\* [3]
21. Define the term wave front. State Huygen's principle.

Consider a plane wave front incident on a thin convex lens. Draw a proper diagram to show how the incident wave front traverses through the lens and after refraction focusses on the focal point of the lens, giving the shape of the emergent wave front. [3]

OR

Explain the following, giving reasons :

- (i) When monochromatic light is incident on a surface separating two media, the reflected and refracted light both have the same frequency as the incident frequency.
- (ii) When light travels from a rarer to a denser medium, the speed decreases. Does this decrease in speed imply a reduction in the energy carried by the wave ?
- (iii) In the wave picture of light, intensity of light is determined by the square of the amplitude of the wave. What determines the intensity in the photon picture of light ?

**Answer :** Wave front : A wave front is the locus of all the points in space that reach a particular distance by a propagating wave in same phase at any instant.

Huygen's principle : It is based on two assumptions :

- (a) Each point of the wavefront behaves like a source of secondary disturbances and secondary wavelets from there points spread out in all directions with the same speed as that of the original wave front.
- (b) When we draw an envelope in the forward direction of the secondary disturbances at any instant, And this envelope tells the new position of the wavefront at that instant.

\*\*Answers is not given due to change in the present syllabus.

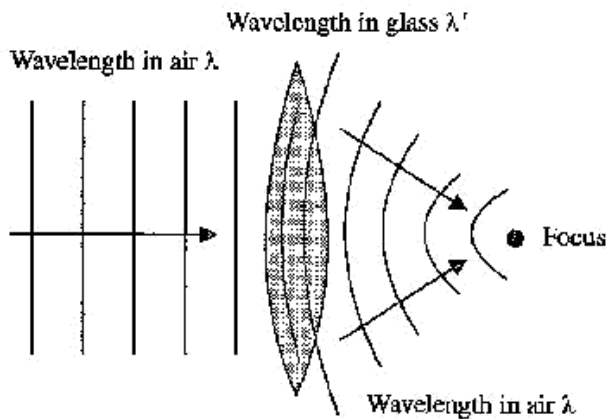

OR

- (i) Both the reflection and refraction takes place due to the interaction of light with the atoms at the surface of the separation. Light incident on these atoms, force them to vibrate with the frequency of light. But, the light emitted by these charged atoms is equal to their own frequency of oscillation. So, both the reflected and refracted lights have same frequency. hence frequency remains changed.
- (ii) The energy carried by a wave depends on the amplitude of the wave. It does not depend on the speed of the wave propagation. Hence the energy of the wave remains same and does not decrease.
- (iii) The intensity of light is determined by the number of photons incident per unit area around the point at which intensity is to be determined.

22. Use Biot-Savart law to derive the expression for the magnetic field on the axis of a current carrying circular loop of radius R.

Draw the magnetic field lines due to a circular wire carrying current I.

[3]

Answer : Imagine a circular coil of radius R with centre O. Let the current flowing through the circular loop be I. Suppose P is any point on the axis at a distance of r from the centre O. Let the circular coil be made up of a large number of small elements of current, each having a length of dl.

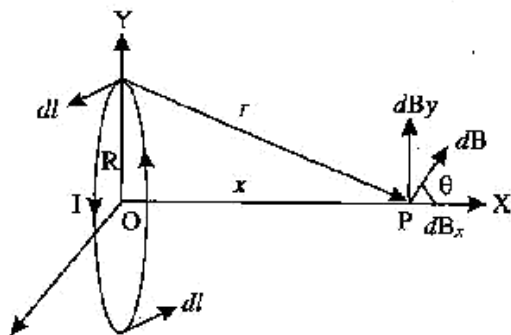

According to Biot-Savart's law, the magnetic field at Point P will be

$$dB = \frac{\mu_0 I}{4\pi} \times \frac{dl \times r}{r^3}$$

where,

$$r^2 = x^2 + R^2$$

$$|dl \times r| = r dl$$

[∵ Both are perpendicular]

Here, r is the position vector of point O from the current element.

$$\text{So, } dB = \frac{\mu_0}{4\pi} \times \frac{I \cdot dl}{r^2}$$

$$dB = \frac{\mu_0}{4\pi} \times \frac{I \cdot dl}{(x^2 + R^2)}$$

dB has two components i.e.,  $dB_x$  and  $dB_y$ .  $dB_y$  is cancelled out and only the x-component remains.

$$\therefore dB_x = dB \cos \theta$$

$$\cos \theta = \frac{R}{\sqrt{x^2 + R^2}}$$

$$dB_x = \frac{\mu_0 I dl}{4\pi} \cdot \frac{R}{(x^2 + R^2)^{3/2}}$$

$$\text{But, } \int dl = 2\pi R$$

$$\text{So, } B = \frac{\mu_0 I R \times 2\pi R}{4\pi(x^2 + R^2)^{3/2}}$$

For n turns in the circular loop,

$$B = \frac{\mu_0 n I R^2}{2(x^2 + R^2)^{3/2}}$$

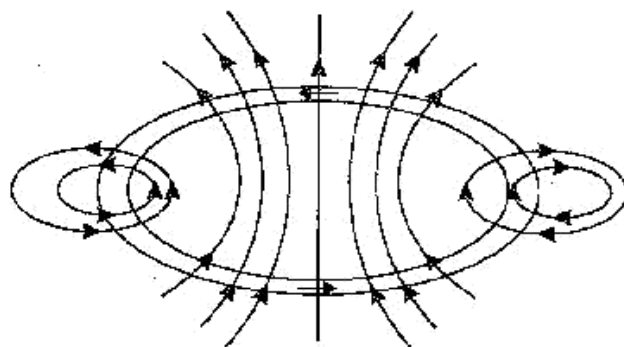

#### SECTION—D $dB_y$

23. Ram is a student of class X in a village school. His uncle gifted him a bicycle with a dynamo fitted in it. He was very excited to get it. While cycling during night, he could light the bulb and see the objects on the road. He, however, did not know how this device works. He asked this question to his teacher. The teacher considered it an opportunity to explain the working to the whole class.

Answer the following questions :

[4]

- (a) State the principle and working of a dynamo.  
 (b) Write two values each displayed by Ram and his school teacher. \*\*

Answer : (a) A dynamo works on the principle of electro-magnetic induction.

A dynamo includes a coil attached to a small turbine fitted with a plastic cap.

The coil is placed in a magnetic field. When the plastic cap comes in contact with moving tyres of the bicycle, the coil placed between the poles of a magnet rotates, thus, the flux through the coil changes continuously. This induces a current in the coil which is connected to a bulb which lights up.

As long as the bicycle is moving, the coil keeps on rotating, and hence, the flux keeps on changing. At a steady rate, we get a steady current and hence a light of steady intensity is obtained.

### SECTION—E

24. (i) Draw a labelled diagram of a step-down transformer. State the principle of its working.  
 (ii) Express the turns ratio in terms of voltages.  
 (iii) Find the ratio of primary and secondary currents in terms of turns ratio in an ideal transformer.  
 (iv) How much current is drawn by the primary of a transformer connected to 220 V supply when it delivers power to a 110 V— 550 W refrigerator ? [5]

OR

- (a) Explain the meaning of the term mutual inductance. Consider two concentric circular coils, one of radius  $r_1$  and the other of radius  $r_2$  ( $r_1 < r_2$ ) placed coaxially with centres coinciding with each other. Obtain the expression for the mutual inductance of the arrangement.  
 (b) A rectangular coil of area A, having number of turns N is rotated at  $f$  revolutions per second in a uniform magnetic field B, the field being perpendicular to the coil. Prove that the maximum emf induced in the coil is  $2\pi f NBA$ .

Answer : (i)

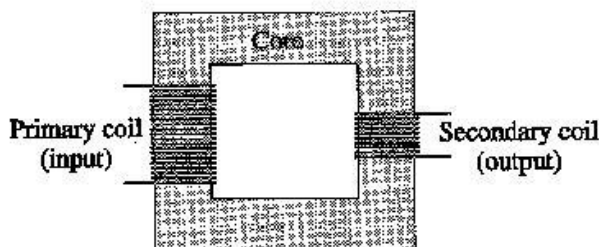

**Principle :** A transformer works on the principle of mutual induction. Whenever the amount of magnetic flux linked with a coil changes, an emf is induced in the neighbouring coil.

**Working :** When an alternating current source is connected to the ends of primary coil, the current changes continuously in the primary coil, due to which magnetic flux linked with the secondary coil changes continuously. Therefore, the alternating emf of same frequency is developed across the secondary terminals. According to Faraday's laws the e.m.f. induced in the primary coil,

$$E_P = -N_P \frac{\Delta\phi}{\Delta t} \quad \dots(i)$$

and emf induced in the secondary coil

$$E_S = -N_S \frac{\Delta\phi}{\Delta t} \quad \dots(ii)$$

From (i) and (ii)

$$\frac{E_S}{E_P} = \frac{N_S}{N_P} = K \quad \dots(iii)$$

For step-down transformer,  $K < 1$ .

$$\therefore E_S < E_P$$

- (ii) The induced emf in primary coil,

$$E_P = -N_P (d\phi/dt)$$

The induced emf in secondary coil,

$$E_S = -N_S (d\phi/dt)$$

$$E_S/E_P = N_S/N_P = K$$

Where K is the turns ratio or the transformation ratio.

- (iii) If the transformer is ideal, then

Input electrical power = Output electrical power

$$E_P I_P = E_S I_S$$

$$E_S/E_P = I_P/I_S$$

$$\frac{I_P}{I_S} = \frac{E_S}{E_P} = \frac{N_S}{N_P} = K$$

- (iv) Given, Power,  $P = 550 \text{ W}$

Supply voltage,  $V_S = 220 \text{ V}$

$$\text{Power} = V_P I_P$$

$$550 = 220 \times I_P$$

$$\Rightarrow I_P = 5/2 = 2.5 \text{ A}$$

OR

- (a) **Mutual inductance :** It is the property of a pair of coils due to which an e.m.f. is induced in one coil due to the change in the flux or current in the other coil.



Let a current  $I_2$  flow through the outer circular coil. The magnetic field at the centre of the coil is

$$B_2 = \frac{\mu_0 I_2}{2r_2} \quad \dots(i)$$

As the inner coil placed co-axially has very small radius, therefore,  $B_2$  may be taken as constant over its cross-sectional area. Hence, flux associated with inner coil is

$$\begin{aligned} \phi_1 &= \pi r_1^2 B_2 \\ &= \pi r_1^2 \frac{\mu_0 I_2}{2r_2} \quad [\text{From (i)}] \end{aligned}$$

$$\begin{aligned} &= \left( \frac{\mu_0 \pi r_1^2}{2r_2} \right) I_2 \\ &= M_{12} I_2 \end{aligned}$$

$$\therefore M_{12} = \frac{\mu_0 \pi r_1^2}{2r_2}$$

$$\text{Now, } M_{21} = M_{12} = \frac{\mu_0 \pi r_1^2}{2r_2}$$

(b) Let  $N$  be the number of turns of the rectangular coil and  $A$  be its cross-sectional area placed in a magnetic field  $B$ , then, the magnetic flux linked with the coil,

$$\phi = NBA \cos \theta$$

The induced emf,

$$e = -d\phi/dt$$

$$e = -\frac{d\phi}{dt} = \left( -NBA(-\sin \theta) \frac{d\theta}{dt} \right)$$

$$\begin{aligned} &= NBA \cdot \sin \theta (2\pi f) \quad \left[ \begin{array}{l} \because \theta = \omega t \\ \frac{d\theta}{dt} = \omega = 2\pi f \end{array} \right] \end{aligned}$$

For maximum induced e.m.f.

$$\sin \theta = 1$$

$$\therefore e = NBA (2\pi f)$$

25. (a) Derive the mathematical relation between refractive indices  $n_1$  and  $n_2$  of two media and radius of curvature  $R$  for refraction at a convex spherical surface. Consider the object to be a point since lying on the principle axis in rarer medium of refractive index  $n_1$  and a real image formed in the denser medium of refractive index  $n_2$ . Hence, derive Lens Maker's formula.

(b) Light from a point source in air falls on a convex spherical glass surface of refractive

index 1.5 and radius of curvature 20 cm. The distance of light source from the glass surface is 100 cm. At what position is the image formed? [5]

OR

(a) Draw a labelled ray diagram to obtain the real image formed by an astronomical telescope in normal adjustment position. Define its magnifying power.

(b) You are given three lenses of power 0.5 D, 4 D and 10 D to design a telescope.

(i) Which lenses should be used as objective and eyepiece? Justify your answer.

(ii) Why is the aperture of the objective preferred to be large?

$$\text{Answer: (a) } \tan \angle NOM = \frac{MN}{OM};$$

$$\tan \angle NCM = \frac{MN}{MC};$$

$$\tan \angle NIM = \frac{MN}{MI}$$

For  $\triangle NOC$ ,  $i$  is the exterior angle.

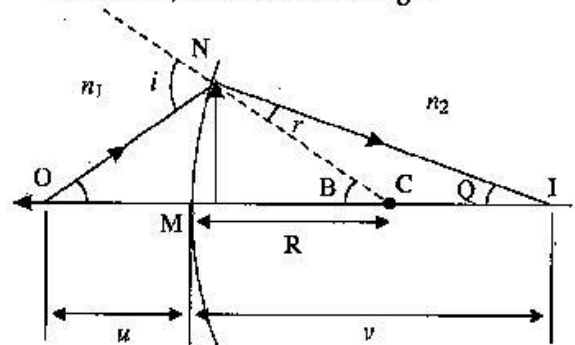

Assuming the incident ray is very close to the principal axis, all the angles are very small. Hence, for very small angles,

$$\tan x = x = \sin x$$

$$\therefore i = \angle NOM + \angle NCM$$

$$i = \frac{MN}{OM} + \frac{MN}{MC} \quad \dots(i)$$

$$\text{Similarly, } r = \angle NCM - \angle NIM$$

$$\text{i.e., } r = \frac{MN}{MC} - \frac{MN}{MI} \quad \dots(ii)$$

By Snell's law,

$$n_1 \sin i = n_2 \sin r$$

For small angles,

$$n_1 i = n_2 r$$

On substituting the values of  $i$  and  $r$  in equations, we get

$$n_1 \left( \frac{MN}{OM} + \frac{MN}{MC} \right) = n_2 \left( \frac{MN}{MC} - \frac{MN}{MI} \right)$$

$$\frac{n_1}{OM} + \frac{n_2}{MI} = \frac{n_2 - n_1}{MC} \quad \dots(iii)$$

On applying new Cartesian sign conventions,

$$OM = -u, MI = +v, MC = +R$$

Substituting these values in equation (iii), we get

$$\frac{n_2}{v} - \frac{n_1}{u} = \frac{n_2 - n_1}{R} \quad \dots(iv)$$

In deriving Lens maker's formula, we adopt the coordinate geometry sign convention and make the assumptions :

- (i) The lens is thin so that the distances measured from the poles of its two surfaces MC can be taken as equal to the distances from its optical centre.
- (ii) The aperture of the lens is small.
- (iii) The object is a point-object placed on the principal axis of the lens.
- (iv) The incident and the refracted rays make small angles with the principal axis.

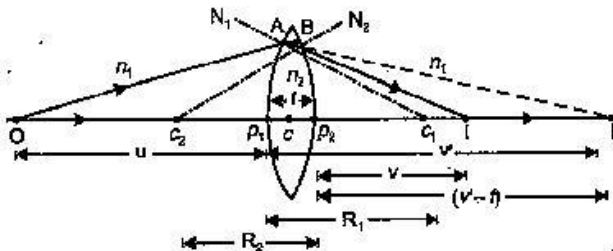

Refraction at the first surface,

$$\frac{n_2}{v'} - \frac{n_1}{u} = \frac{n_2 - n_1}{R_1}$$

Refraction at the second surface,

$$\frac{n_1}{v} - \frac{n_2}{v-t} = \frac{n_1 - n_2}{R_2}$$

The lens is 'thin', hence  $t \ll v'$  and can be ignored. Then, we have

$$\frac{n_1}{v} - \frac{n_2}{v'} = \frac{n_1 - n_2}{R_2} \quad \dots(ii)$$

Adding equation (i) and (ii), we get

$$\frac{n_1}{v} - \frac{n_1}{u} = (n_2 - n_1) \left( \frac{1}{R_1} - \frac{1}{R_2} \right)$$

Putting  $n_2/n_1 = n$ , the refractive index of the material of the lens with respect to the surrounding medium, we have

$$\frac{1}{v} - \frac{1}{u} = (n-1) \left( \frac{1}{R_1} - \frac{1}{R_2} \right) \quad \dots(iii)$$

When the object is at infinity, the image will be formed at the principal focus of the lens, i.e., when  $u = \infty$ ,

$$\frac{1}{f} - \frac{1}{\infty} = (n-1) \left( \frac{1}{R_1} - \frac{1}{R_2} \right)$$

$$\frac{1}{f} = (n-1) \left( \frac{1}{R_1} - \frac{1}{R_2} \right)$$

This is the Lens Maker's formula.

(b) Given, refractive index,  $n_2 = 1.5, n_1 = 1$  (air)

Radius of curvature,  $R = 20$  cm

Object distance,  $u = -100$  cm

To find, Image distance,  $v$

$$\frac{n_2}{v} - \frac{n_1}{u} = \frac{n_2 - n_1}{R}$$

$$\frac{1.5}{v} + \frac{1}{(100)} = \frac{1.5 - 1}{20} = \frac{1}{40}$$

$$\frac{1.5}{v} = \frac{1}{40} - \frac{1}{100} = \frac{5 - 2}{200} = \frac{3}{200}$$

$$v = \frac{200}{3} \times 1.5 = 100 \text{ cm}$$

The image is formed at 100 cm in denser medium.

OR

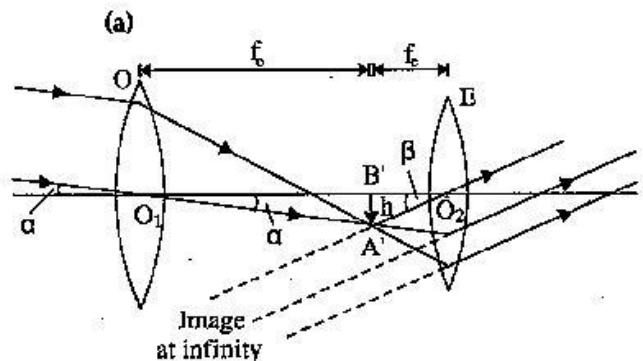

**Magnifying power :** The magnifying power of a refracting type astronomical telescope is defined as the ratio of angle subtended by the final image at eye to the angle subtended by the object at eye.

(b) (i) We know that,

$$\text{Magnification, } m = \frac{f_o}{f_e} = \frac{P_e}{P_o}$$

Therefore, the lens of 0.5 D should be used as objective and the lens of 10 D should be used as eye-piece in order to achieve higher magnification.

- (ii) The aperture of the objective lens is made larger so, that it receives as much light as coming from the distant object and the resolving power of the telescope increases.

26. (i) Use Gauss's law to find the electric field due to a uniformly charged infinite plane sheet. What is the direction of field for positive and negative charge densities ?

- (ii) Find the ratio of the potential differences that must be applied across the parallel and series combination of two capacitors  $C_1$  and  $C_2$  with their capacitances in the ratio 1 : 2 so that the energy stored in the two cases becomes the same. [5]

OR

- (i) If two similar large plates, each of area  $A$  having surface charge densities  $+\sigma$  and  $-\sigma$  are separated by a distance in air, find the expressions for

- field at points between the two plates and on outer side of the plates. Specify the direction of the field in each case.
- the potential difference between the plates.
- the capacitance of the capacitor so formed.

- (ii) Two metallic spheres of radii  $R$  and  $2R$  are charged so that both of these have same surface charge density  $\sigma$ . If they are connected to each other with a conducting wire, in which direction will the charge flow and why ?

Answer : (i)

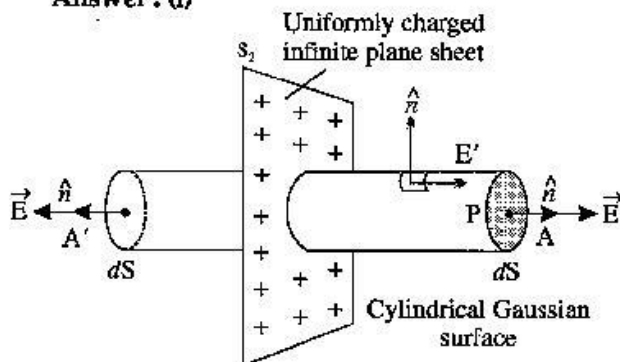

Consider a thin infinite uniformly charged plane sheet having the surface charge density of  $\sigma$ . The electric field is normally outward to the plane sheet and is same in magnitude but opposite in direction.

Now, draw a Gaussian surface in the form of cylinder around an axis. Let its cross-sectional

area be  $A$ . The cylinder is made from three surfaces  $A$ ,  $S_2$ , and  $A'$  and the electric flux linked with  $S_2$  is 0. So, the total electric flux linked through the Gaussian surface is

$\phi_E =$  electric flux through  $A$  + electric flux through  $S_2$  + electric flux through  $A'$

$$\phi_E = EA \cos 0^\circ + 0 + EA \cos 0^\circ.$$

$$\phi = 2EA \quad \dots(i)$$

According to Gauss theorem,

$$\phi = \frac{q}{\epsilon_0}$$

$$\phi = \frac{\sigma A}{\epsilon_0} \quad (\because q = \sigma A) \dots(ii)$$

From equations (i) and (ii)

$$2EA = \frac{\sigma A}{\epsilon_0}$$

$$E = \frac{\sigma}{2\epsilon_0}$$

The direction of field for positive charge density is in outward direction away from sheet and perpendicular to the plane infinite sheet whereas for the negative charge density the direction becomes inward *i.e.*, towards the sheet and perpendicular to the sheet.

- (ii) Given  $C_1 : C_2 = 1 : 2$

$$\Rightarrow C_2 = 2C_1$$

For parallel combination of capacitor,

$$C_p = C_1 + C_2 \\ = C_1 + 2C_1 = 3C_1$$

The energy stored in capacitor

$$E = \frac{1}{2} C_p V_p^2 \\ = \frac{1}{2} 3C_1 V_p^2 = \frac{3}{2} C_1 V_p^2 \quad \dots(i)$$

For series combination of capacitor,

$$\frac{1}{C_s} = \frac{1}{C_1} + \frac{1}{C_2}$$

$$C_s = \frac{2}{3} C_1$$

The energy stored in capacitor

$$E = \frac{1}{2} C_s V_s^2 \\ E = \frac{C_1 V_s^2}{3} \quad \dots(ii)$$

Equating equation (i) and (ii), since energy stored in both cases are same

we get,

$$\frac{3}{2} C_1 V_p^2 = \frac{C_1 V_s^2}{3}$$

$$\frac{V_p}{V_s} = \frac{\sqrt{2}}{3}$$

OR

- (i) (a) Consider a parallel plate capacitor with two identical plates X and Y, each having an area of A, and separated by a distance d. Let the space between the plates be filled by a dielectric medium with its dielectric constant as K and  $\sigma$  be the surface charge density on each of the plates.

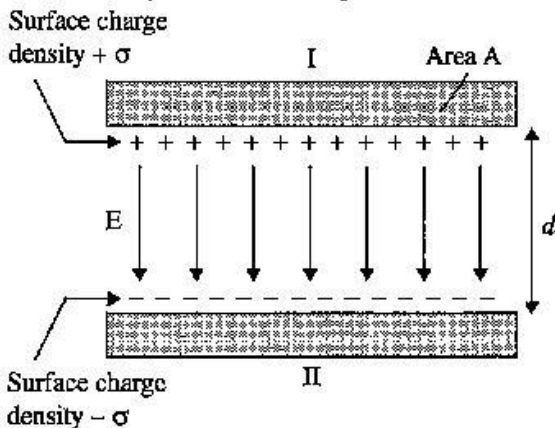

Surface charge density of plate I

$$\sigma = Q/A$$

and that of plate II is  $-\sigma$ .

Electric field in outer region I,

$$E = \frac{\sigma}{2\epsilon_0} - \frac{\sigma}{2\epsilon_0} = 0$$

Electric field in outer region II,

$$E = \frac{\sigma}{2\epsilon_0} - \frac{\sigma}{2\epsilon_0} = 0$$

In the inner region between plates 1 and 2, the electric fields due to the two charged plates add up. So

$$E = \frac{\sigma}{2\epsilon_0} + \frac{\sigma}{2\epsilon_0} = \frac{\sigma}{\epsilon_0}$$

- (b) For uniform electric field, potential difference is simply the electric field multiplied by the distance between the plates, i.e.,

$$V = Ed = \frac{1}{\epsilon_0} \frac{Qd}{A}$$

- (c) Now, the capacitance of the parallel plate capacitor,

$$C = \frac{Q}{V} = \frac{Q \cdot \epsilon_0 A}{Qd} = \frac{\epsilon_0 A}{d}$$

- (ii) We know that the potential difference of the metallic sphere is given by,

$$V = \frac{Q}{4\pi\epsilon_0 r}$$

where  $r$  is the radius of the sphere.

Now, the potential of the metallic sphere of radius  $R$  is given by,

$$V_R = \frac{Q}{4\pi\epsilon_0 r}$$

$$V_R = \frac{\sigma(4\pi R^2)}{4\pi\epsilon_0 R}$$

$$V_R = \frac{\sigma R}{\epsilon_0} \quad \dots(i)$$

Similarly, the potential of the metallic sphere of radius  $V_{2R}$  is given by

$$V_{2R} = \frac{Q}{4\pi\epsilon_0 2R}$$

$$V_{2R} = \frac{\sigma(4\pi (2R)^2)}{4\pi\epsilon_0 2R}$$

$$V_{2R} = \frac{\sigma 2R}{\epsilon_0} \quad \dots(ii)$$

From the relation (i) and (ii) we know that  $V_{2R} > V_R$ .

The charge will flow from the sphere of radius of  $2R$  to the sphere of radius  $R$ , if the spheres are connected.

••

## Physics 2016 (Delhi)

## SET I

Time allowed : 3 hours

Maximum marks : 70

### SECTION – A

1. A point charge  $+Q$  is placed at point O as shown in the figure. Is the potential difference  $V_A - V_B$  positive, negative or zero? [1]



Answer : Potential at a distance  $r$  from a given point charge  $Q$  is given by

$$V = \frac{1}{4\pi\epsilon_0} \frac{Q}{r}$$

$$V_A = \frac{1}{4\pi\epsilon_0 r_A}$$

$$V_B = \frac{Q}{4\pi\epsilon_0 r_B}$$



Since  $r_A < r_B$   
 $\Rightarrow V_A > V_B$

Hence,  $V_A - V_B$  is positive.

2. How does the electric flux due to a point charge enclosed by a spherical Gaussian surface get affected when its radius is increased? [1]

Answer : According to Gauss's law

$$\phi = \int \vec{E} \cdot d\vec{s} = \frac{q_{en}}{\epsilon_0}$$

Flux depends only on the charge enclosed and not on the radius.

Hence, the electric flux remains constant.

3. Write the underlying principle of a moving coil galvanometer. [1]

Answer : When a current carrying coil is placed in magnetic field then it experiences a torque.

$$NIAB = k\alpha$$

$$\Rightarrow I = \frac{k}{NAB} \alpha$$

where  $N$  = The number of turns.

$I$  = Current.

$A$  = Area of the loop.

$B$  = Magnetic field.

$k$  = Torsional constant of the wire

$\alpha$  = Angle of deflection

4. Why are microwaves considered suitable for radar systems used in aircraft navigation? [1]

Answer : Microwaves are considered suitable because they have a short wavelength range they are suitable for radar system used in aircraft navigation.

5. Define 'quality factor' of resonance in series LCR circuit. What is its SI unit? [1]

Answer : The Q factor of series resonance circuit is defined as the ratio of the voltage developed across the inductor or capacitor at resonance to the impressed voltage, which is the voltage across R.

$$Q = \frac{1}{R} \sqrt{\frac{L}{C}}$$

It is dimensionless quantity. Hence, it has no units.

### SECTION-B

6. Explain the terms (i) Attenuation and (ii) Demodulation used in Communication System. [2]

Answer : (i) Attenuation : The loss of strength of a signal while propagating through a medium is known as attenuation.

(ii) Demodulation : The process of retrieval of information from the carrier wave at the receiver end is termed as demodulation. This is the reverse process of modulation.

7. Plot a graph showing variation of de-Broglie wavelength  $\lambda$  versus  $\frac{1}{\sqrt{V}}$ , where  $V$  is accelerating potential for two particles A and B carrying same charge but of masses  $m_1, m_2$  ( $m_1 > m_2$ ). Which one of the two represents a particle of smaller mass and why? [2]

Answer : We know that,

$$qV = \frac{1}{2} mv^2$$

$$qV = \frac{p^2}{2m}$$

$$\Rightarrow p = \sqrt{2mqV}$$

$$= \frac{h}{\lambda}$$

$$\Rightarrow \lambda = \frac{h}{\sqrt{2mqV}}$$

$$\Rightarrow \text{Slope} \propto \frac{1}{\sqrt{m}}$$

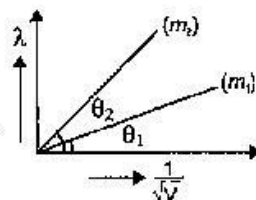

Hence, the particle with lower mass ( $m_2$ ) will have greater slope.

8. A nucleus with mass number  $A = 240$  and  $BE/A = 7.6$  MeV breaks into two fragments each of  $A = 120$  with  $BE/A = 8.5$  MeV. Calculate the released energy. [2]

OR

Calculate the energy in fusion reaction :

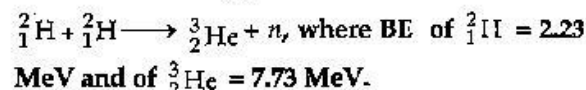

Answer : Binding energy of the nucleus,

$$B_1 = 7.6 \times 240 = 1824 \text{ MeV.}$$

Binding energy of each product nucleus,

$$B_2 = 8.5 \times 120 = 1020 \text{ MeV}$$

Then, energy released as the nucleus breaks,

$$E = 2 B_2 - B_1 = 2 \times 1020 - 1824 = 216 \text{ MeV.}$$

OR

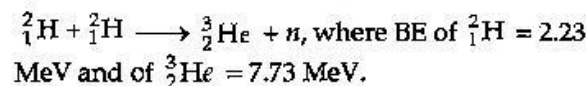

The energy released in the fusion reaction is

$$\Delta E = (7.73) - 2(2.23)$$

$$= 7.73 - 4.46$$

$$= 3.27 \text{ MeV}$$

9. Two cells of emfs 1.5 V and 2.0 V having internal resistances 0.2  $\Omega$  and 0.3  $\Omega$  respectively are connected in parallel. Calculate the emf and internal resistance of the equivalent cell. [2]

Answer : Given,  $E_1 = 1.5 \text{ V}$ ,  $r_1 = 0.2 \Omega$ ,

$$E_2 = 2 \text{ V}, r_2 = 0.3 \Omega$$

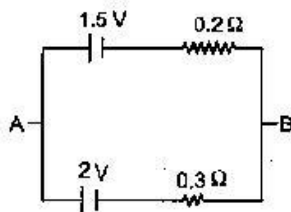

$$\begin{aligned} \text{Equivalent emf, } E &= \frac{\frac{E_1}{r_1} + \frac{E_2}{r_2}}{\frac{1}{r_1} + \frac{1}{r_2}} \\ &= \frac{(1.5 \times 0.3) + (2 \times 0.2)}{0.2 + 0.3} \\ &= \frac{0.45 + 0.4}{0.5} \\ &= \frac{0.85}{0.5} = 1.7 \text{ volt} \end{aligned}$$

Equivalent internal resistance

$$\begin{aligned} &= \frac{r_1 r_2}{r_1 + r_2} \\ &= \frac{0.2 \times 0.3}{0.2 + 0.3} \\ &= \frac{0.06}{0.5} \end{aligned}$$

$$r_{eq} = 0.12 \Omega$$

10. State Brewster's law.

The value of Brewster angle for a transparent medium is different for light of different colours. Give reason. [2]

Answer : Brewster's law : The law states that the tangent of the polarising angle of incidence for a given medium is equal to the refractive index of the medium. The light incident at this angle when reflects back is perfectly polarised.

i.e.  $\mu = \tan i_p$

The refractive index of a material depends on the colour or wavelength of light. As the polarising angle depends on refractive index ( $\mu = \tan i_p$ ), so it also depends on wavelength of light.

### SECTION-C

11. A charge is distributed uniformly over a ring of radius 'a'. Obtain an expression for the electric intensity E at a point on the axis of the ring.

Hence show that for points at large distances from the ring, it behaves like a point charge. [3]

Answer : Suppose we have a ring of radius a that carries a uniformly distributed positive charge q.

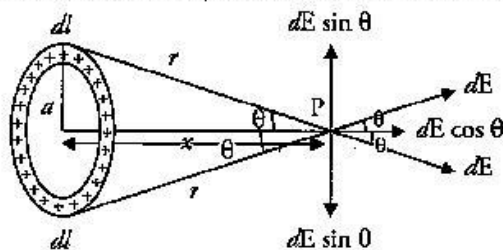

As the total charge q is uniformly distributed, the charge dq on the element dl is

$$dq = \frac{q}{2\pi a} \cdot dl$$

\(\therefore\) The magnitude of the electric field produced by the element dl at the axial point P is

$$dE = k \cdot \frac{dq}{r^2} = \frac{kq}{2\pi a} \cdot \frac{dl}{r^2}$$

The electric field dE has two components.

- (i) The axial components  $dE \cos \theta$  and
- (ii) The perpendicular component  $dE \sin \theta$ .

Since the perpendicular component of any two diametrically opposite elements are equal and opposite, they cancel out in pairs. Only the axial components will add up to produce the resultant field.

E at point P is given by

$$E = \int_0^{2\pi a} dE \cos \theta$$

[ $\therefore$  Only the axial components contribute towards E]

$$E = \int_0^{2\pi a} \frac{kq}{2\pi a} \cdot \frac{dl}{r^2} \cdot \frac{x}{r} \quad \left[ \because \cos \theta = \frac{x}{r} \right]$$

$$= \frac{kqx}{2\pi a} \cdot \frac{1}{r^3} \int_0^{2\pi a} dl$$

$$= \frac{kqx}{2\pi a} \cdot \frac{1}{r^3} (l)_0^{2\pi a}$$

$$= \frac{kqx}{2\pi a} \cdot \frac{1}{(x^2 + a^2)^{3/2}} \cdot 2\pi a \quad \left[ \because r^2 = x^2 + a^2 \right]$$

$$E = \frac{kqx}{(x^2 + a^2)^{3/2}}$$

[where  $k = \frac{1}{4\pi\epsilon_0}$  a = constant]

$$= \frac{1}{4\pi\epsilon_0} \cdot \frac{qx}{(x^2 + a^2)^{3/2}}$$

If  $x \gg a$ , then  $x^2 + a^2 \approx x^2$

$$E = \frac{1}{4\pi\epsilon_0} \frac{qx}{(x^2)^{3/2}}$$

$$E = \frac{1}{4\pi\epsilon_0} \frac{q}{x^2}$$

This expression is similar to electric field due to a point charge.

12. Write three characteristic features in photoelectric effect which cannot be explained on the basis of wave theory of light, but can be explained only using Einstein's equation. [3]

**Answer :** (i) **Existence of threshold frequency :** According to wave theory, there should not exist any threshold frequency but Einstein's theory explains the existence of threshold frequency.

(ii) **Dependence of kinetic energy on frequency of incident light :** According to wave theory, the maximum kinetic energy of emitted electrons should depend on intensity of incident light and not on frequency whereas Einstein's equation explains that it dependence on frequency and not on intensity of the incident light.

(iii) **Instantaneous emission of electrons :** According to wave theory there should be time lag between emission of electrons and incident of light whereas Einstein's equation explains why there is no time lag between incident of light and emission of electrons.

13. (a) Write the expression for the magnetic force acting on a charged particle moving with velocity  $v$  in the presence of magnetic field  $B$ .
- (b) A neutron, an electron and an alpha particle moving with equal velocities, enter a uniform magnetic field going into the plane of the paper as shown. Trace their paths in the field and justify your answer. [3]

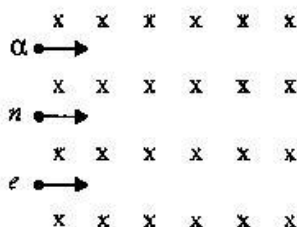

**Answer :** (a) A charge particle having charge  $q$  is moving with velocity ' $v$ ' in a magnetic field of field strength ' $B$ ' then the force acting on it is given by the formula  $F = q(\vec{v} \times \vec{B})$  and  $F = qvB \sin \theta$  (where  $\theta$  is the angle between velocity vector and magnetic field).

Direction of force is given by the cross product of velocity and magnetic field.

(b)

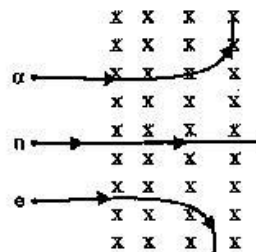

$\alpha$  particle will trace circular path in anticlockwise direction as it's deviation will be in the direction of  $(\vec{v} \times \vec{B})$ .

Neutron will pass without any deviation as magnetic field does not exert any force on neutral particle.

Electron will trace circular path in clockwise direction as its deviation will be in the direction opposite to  $(\vec{v} \times \vec{B})$  with a smaller radius due to large charge/mass ratio as  $r = \frac{mv}{qB}$ .

14. (a) Define mutual inductance.
- (b) A pair of adjacent coils has a mutual inductance of 1.5 H. If the current in one coil changes from 0 to 20 A in 0.5 s, what is the change of flux linkage with the other coil? [3]

**Answer :** (a) Mutual induction is the phenomenon of production of induced emf in one coil due to change of current or flux in the neighbouring coil. The coil in which the current changes is called primary coil and the coil in which emf is induced is called the secondary coil.

(b)

$$M = 1.5 \text{ H}$$

$$I_1 = 0 \text{ A}$$

$$I_2 = 20 \text{ A}$$

$$\Delta I = 20 \text{ A}, \quad \Delta t = 0.5 \text{ s}$$

$$e = \frac{-M \Delta I}{\Delta t}$$

$$= -1.5 \times \frac{20}{0.5}$$

$$= -60 \text{ V}$$

So the flux linked with the other coil is given by

$$\Delta \Phi = -e \Delta t = 60 \times 0.5$$

$$= 30 \text{ Wb.}$$

15. Two parallel plate capacitors X and Y have the same area of plates and same separation between them. X has air between the plates while Y contains a dielectric medium of  $\epsilon_r = 4$ . [3]

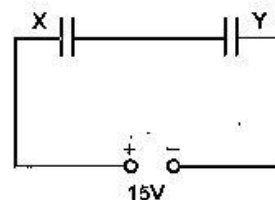

- (i) Calculate capacitance of each capacitor if equivalent capacitance of the combination is  $4 \mu\text{F}$ .
- (ii) Calculate the potential difference between the plates of X and Y.
- (iii) Estimate the ratio of electrostatic energy stored in X and Y.

Answer : (i) Let capacitance of X be  $C_1$  and capacitance of Y be  $C_2$ .

$$C_1 = \frac{\epsilon_0 A}{d}$$

$$C_2 = \frac{\epsilon_r \epsilon_0 A}{d}$$

Taking the ratio of  $C_1$  and  $C_2$

$$\frac{C_1}{C_2} = \frac{1}{\epsilon_r}$$

$$\Rightarrow C_2 = \epsilon_r C_1$$

$$\text{Let } C_1 = C$$

$$\text{Then } C_2 = 4C \quad (\because \epsilon_r = 4)$$

Since two capacitance are connected in series so, equivalent capacitance will be

$$\frac{1}{C_{eq}} = \frac{1}{C_1} + \frac{1}{C_2}$$

$$C_{eq} = \frac{C_1 C_2}{C_1 + C_2}$$

$$4 \mu\text{F} = \frac{C \times 4C}{C + 4C}$$

$$\Rightarrow C = 5 \mu\text{F}$$

$$\text{So, } C_1 = 5 \mu\text{F and } C_2 = 20 \mu\text{F}$$

$$(ii) C_{eq} V_{net} = Q_{Total}$$

$$4 \mu\text{F} \times 15\text{V} = Q_{Total}$$

$$Q_{Total} = 60 \mu\text{C}$$

Since in series configuration charge on each capacitor is equal.

$$\text{Hence, } Q_1 = Q_2 = Q_{Total} = 60 \mu\text{C}$$

$$\text{Using, } Q = CV$$

$$V_1 = \frac{Q_1}{C_1} = \frac{60 \mu\text{C}}{5 \mu\text{F}} = 12 \text{V}$$

$$V_2 = \frac{Q_2}{C_2} = \frac{60 \mu\text{C}}{20 \mu\text{F}} = 3 \text{V}$$

$$(iii) U_1 = \frac{1}{2} \frac{Q_1^2}{C_1} = \frac{1}{2} \frac{(60 \mu\text{C})^2}{5 \mu\text{F}} = 360 \mu\text{J}$$

$$U_2 = \frac{1}{2} \frac{Q_2^2}{C_2} = \frac{1}{2} \frac{(60 \mu\text{C})^2}{20 \mu\text{F}} = 90 \mu\text{J}$$

$$\Rightarrow \frac{U_1}{U_2} = \frac{4}{1}$$

$$\Rightarrow U_1 : U_2 = 4 : 1$$

16. Two long straight parallel conductors carry steady current  $I_1$  and  $I_2$  separated by a distance  $d$ . If the currents are flowing in the same direction, show how the magnetic field set up if one produces an attractive force on the other. Obtain the expression for this force. Hence define one ampere. [3]

Answer : Magnetic field produced on the wire (carrying current  $I_2$ ) due to  $I_1$  will be

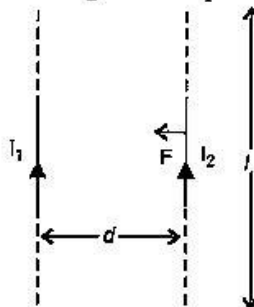

$$B = \frac{\mu_0 I_1}{2\pi d}$$

Force acting at  $l$  length is

$$F = I_2 l B$$

$$F = \frac{\mu_0 I_1 I_2 l}{2\pi d} \text{ towards } I_1$$

If  $l = 1 \text{ m}$ ,  $d = 1 \text{ m}$ ,  $I_1 = I_2 = I$  and  $F = 2 \times 10^{-7} \text{ N}$

$$\Rightarrow I = 1 \text{ A}$$

So one ampere is defined as the current, which when maintained in two parallel infinite length conductors, held at a separation of one metre will produce a force of  $2 \times 10^{-7} \text{ N}$  per metre on each conductor.

17. How are e.m. waves produced by oscillating charges ?

Draw a sketch of linearly polarized e.m. waves propagating in the Z-direction. Indicate the directions of the oscillating electric and magnetic fields. [3]

OR

Write Maxwell's generalization of Ampere's circuital law. Show that in the process of charging a capacitor, the current produced

within the plates of the capacitor is  $i = \epsilon_0 \frac{d\phi_E}{dt}$

where  $\phi_E$  is the electric flux produced during charging of the capacitor plates.

Answer : A charge oscillating with some frequency, produces an oscillating electric field in space, which in turn produces an oscillating magnetic field perpendicular to the electric field. This process goes on repeating, producing e.m. waves in space perpendicular to both the fields.

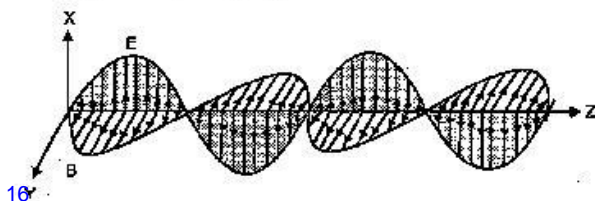



The direction of electric and magnetic fields are perpendicular to each other and are also perpendicular to the direction of propagation of the wave.

OR

**Correction in Ampere's circuital law (Modified Ampere's law) :** Maxwell removed the problem of current continuity and inconsistency observed in Ampere's circuital law by introducing the concept of displacement current. Displacement current arises due to change in electric flux with time and is given by  $i_d = \epsilon_0 \frac{d\phi_E}{dt}$

Electric flux through the loop<sup>4</sup>

$$\begin{aligned}\phi_E &= EA \\ &= \frac{\sigma}{\epsilon_0} A = \frac{Q}{A \epsilon_0} A = \frac{Q}{\epsilon_0}\end{aligned}$$

(where, Q = charge on either plates)

$$\begin{aligned}\phi_E &= \frac{Q}{\epsilon_0} \\ \frac{d\phi_E}{dt} &= \frac{1}{\epsilon_0} \frac{dQ}{dt} \\ \epsilon_0 \frac{d\phi_E}{dt} &= \frac{dQ}{dt}\end{aligned}$$

$\frac{dQ}{dt}$  is called conduction current which is equal to  $\epsilon_0 \frac{d\phi_E}{dt}$  which is displacement current.

Hence,  $i_c = i_d$

Generalization of Ampere's circuital law is :

$$\oint \vec{B} \cdot d\vec{c} = \mu_0 (i_c + i_d)$$

Conduction current is due to the flow of charges but displacement current is not because of the flow of charges but it is due to the change in electric flux.

18. (a) Explain any two factors which justify the need of modulating a low frequency signal.  
(b) Write two advantages of frequency modulation over amplitude modulation. [3]

**Answer : (a) 1. Size of Antenna :** The size of antenna required will be of order of  $\lambda/4$ . When frequency is small, the height of antenna should be large. So audio frequency signal should be modulated over a high frequency carrier wave to increase its frequency.

**2. Effective power radiated by an Antenna :** As power radiated  $\propto \frac{1}{\lambda^2}$ , hence when frequency is increased then the power radiated will be more.

(b) Advantages of frequency modulation over

amplitude modulation :

- Noise can be reduced.
  - Transmission efficiency is more because the amplitude of an FM wave is constant.
19. (a) Write the functions of three segments of a transistor.\*\*  
(b) Draw the circuit diagram for studying the input and output characteristics of *n-p-n* transistor in common emitter configuration. Using the circuit, explain how input, output characteristics are obtained.\*\* [3]
20. (a) Calculate the distance of an object of height *h* from a concave mirror of radius of curvature 20 cm, so as to obtain a real image of magnification 2. Find the location of image also.  
(b) Using mirror formula, explain why does a convex mirror always produce a virtual image. [3]

**Answer :** (a) Given, Height of object = *h*

Radius of curvature = - 20 cm

Magnification, *m* = - 2

Object distance, *u* = ?

Image distance, *v* = ?

$$\text{Magnification, } M = \frac{-v}{u} = \frac{h_i}{h_o}$$

$$-2 = -\frac{v}{u}$$

$$v = 2u \quad \dots(i)$$

Using mirror formula,

$$\frac{1}{v} + \frac{1}{u} = \frac{1}{f}$$

$$\frac{1}{2u} + \frac{1}{u} = \frac{-2}{20}$$

$$\frac{+3}{2u} = \frac{-2}{20}$$

$$u = -\frac{60}{4} = -15 \text{ cm}$$

Putting in (i), we get

$$\begin{aligned}v &= 2 \times -15 \text{ cm} \\ &= -30 \text{ cm}\end{aligned}$$

$$\frac{h_i}{h_o} = \left| \frac{v}{u} \right|$$

$$\frac{h_i}{h} = \left| \frac{2u}{u} \right|$$

Height of image,  $h_i = 2h$  when object is placed at 15 cm from the mirror.

(b) For convex mirror,

$$f = +ve \text{ (always)}$$

Mirror formula,

$$\frac{1}{v} + \frac{1}{u} = \frac{1}{f}$$

$$\frac{1}{v} = \frac{1}{f} \frac{1}{u}$$

As,  $u = -ve$  (for real object)

$$\frac{1}{v} = \frac{1}{f} \left( \frac{1}{u} \right)$$

$$\frac{1}{v} = \frac{1}{f} + \frac{1}{u}$$

$$v = +ve$$

Hence, it will form virtual and erect image.

21. (a) State Bohr's quantization condition for defining stationary orbits. How does de-Broglie hypothesis explain the stationary orbits?

(b) Find the relation between the three wavelengths  $\lambda_1$ ,  $\lambda_2$  and  $\lambda_3$  from the energy level diagram shown below. [3]

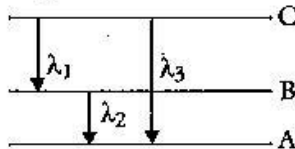

**Answer :** (a) **Quantization condition :** Of all possible circular orbits allowed by the classical theory, the electrons are permitted to circulate only in those orbits in which the angular momentum of an electron is an integral multiple of  $\frac{h}{2\pi}$ ;  $h$  being Planck's constant.

Therefore, for any permitted orbit,

$$L = mvr = \frac{nh}{2\pi}; n = 1, 2, 3, \dots$$

Where  $L$ ,  $m$ , and  $v$  are the angular momentum, mass and speed of the electron respectively,  $r$  is the radius of the permitted orbit and  $n$  is positive integer called principle quantum number.

The above equation is Bohr's famous quantum condition. When an electron of mass  $m$  is confined to move in a line of length  $l$  with velocity  $v$ , the de-Broglie wavelength  $\lambda$  associated with electron is:

$$\lambda = \frac{h}{mv} = \frac{h}{p}$$

or  $p = \text{Linear momentum}$

$$\Rightarrow p = \frac{h}{\lambda} = \frac{h}{2l/n} = \frac{nh}{2l}$$

When electron revolves in a circular orbit of radius ' $r$ ' then  $2l = 2\pi r$ .

$$\therefore p = \frac{nh}{2\pi r} \text{ or } p \times r = \frac{nh}{2\pi}$$

or angular momentum  $\left| \vec{L} \right| = p \times r$  is an integral

multiple of  $h/2\pi$ , which is Bohr's quantisation of angular momentum.

$$(b) E_{CB} = \frac{hc}{\lambda_1}$$

$$E_{BA} = \frac{hc}{\lambda_2}$$

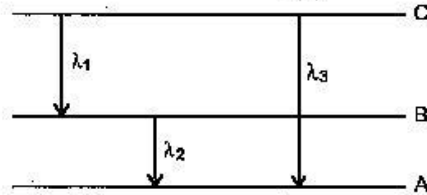

$$E_{CA} = \frac{hc}{\lambda_3}$$

Now,

$$E_{CA} = E_{CB} + E_{BA}$$

where  $E_{CB}$  = Energy gap between level B and C,

$E_{BA}$  = Energy gap between level A and B,

$E_{CA}$  = Energy gap between level A and C.

$$\frac{hc}{\lambda_3} = \frac{hc}{\lambda_1} + \frac{hc}{\lambda_2}$$

$$\frac{1}{\lambda_3} = \frac{1}{\lambda_1} + \frac{1}{\lambda_2}$$

$$\lambda_3 = \frac{\lambda_1 \lambda_2}{\lambda_2 + \lambda_1}$$

22. Draw a schematic ray diagram of reflecting telescope showing how rays coming from a distant object are received at the eye-piece. Write its two important advantages over a refracting telescope. [3]

**Answer :** **Reflecting Telescope :** The reflecting telescope make use of a concave mirror as objective. The rays of light coming from distant object are incident on the objective (parabolic reflector). After reflection the rays of light meet at a point where another convex mirror is placed. This mirror focusses light inside the telescope tube. The final image is seen through the eye-piece. The images produced by the reflecting telescope is very bright and its resolving power is high.

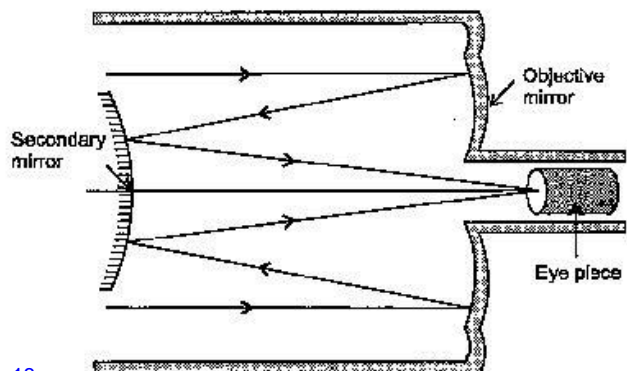

**Advantages :**

- The resolving power (the ability to observe two object distinctly) is high, due to the large diameter of the objective.
- There is no chromatic aberration as the object is a mirror.

**SECTION - D**

23. Meeta's father was driving her to the school. At the traffic signal she noticed that each traffic light was made of many tiny lights instead of a single bulb. When Meeta asked this question to her father, he explained the reason for this.

Answer the following questions based on above information:

- What were the values displayed by Meeta and her father?\*
- What answer did Meeta's father give ?
- What are the tiny lights in traffic signals called and how do these operate ? [4]

Answer :

(ii) Meeta's father said that these are LED light which consume less power and have high reliability.

(iii) The tiny lights in traffic signals are Light Emitting Diode. These are operated by connecting the p-n junction diode in forward biased condition.

**SECTION-E**

24. (a) An a.c. source of voltage  $V = V_0 \sin \omega t$  is connected to a series combination of L, C and R. Use the phasor diagram to obtain expressions for impedance of the circuit and phase angle between voltage and current. Find the condition when current will be in phase with the voltage. What is the circuit in this condition called ?

(b) In a series LR circuit  $X_L = R$  and power factor of the circuit is  $P_1$ . When capacitor with capacitance C such that  $X_L = X_C$  is put in series, the power factor becomes  $P_2$ . Calculate  $P_1/P_2$ . [5]

OR

(a) Write the function of a transformer. State its principle of working with the help of a diagram. Mention various energy losses in this device.

(b) The primary coil of an ideal step up transformer has 100 turns and transformation ratio is also 100. The input voltage and power are respectively 220 V and 1100 W. Calculate :

- number of turns in secondary.
- current in primary.
- voltage across secondary.
- current in secondary.

**(v) power in secondary.**

Answer : (a) Let a series LCR circuit is connected to an a.c. source V (Fig). We take the voltage of the source to be  $V = V_0 \sin \omega t$

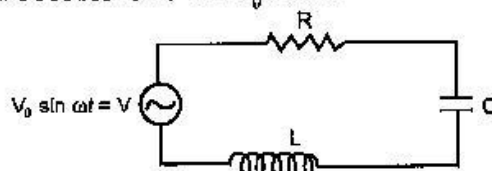

The a.c. current in each element is the same at any time, having the same amplitude and phase. It is given by,

$$I = I_0 \sin (\omega t + \phi)$$

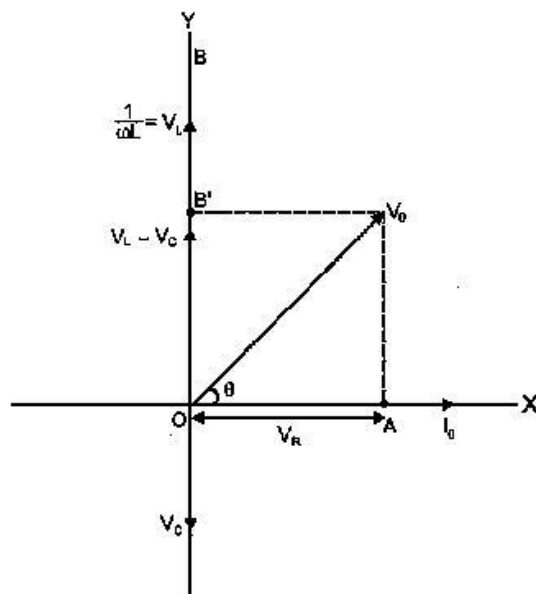

Phasor diagram for LCR circuit

Let  $V_L, V_R, V_C$  and  $V$  represent the voltage across the inductor, resistor, capacitor and the source respectively. But  $V_L = I_0 X_L, V_R = I_0 R$  and  $V_C = I_0 X_C$

Let  $V_L > V_C$

$$\therefore V_0^2 = V_R^2 + (V_L - V_C)^2$$

$$V_0^2 = (I_0 R)^2 + (I_0 X_L - I_0 X_C)^2$$

$$V_0^2 = I_0^2 [R^2 + (X_L - X_C)^2]$$

and 
$$I_0 = \frac{V_0}{\sqrt{R^2 + (X_L - X_C)^2}}$$

$$\Rightarrow I_0 = \frac{V_0}{Z}$$

Where 
$$Z = \sqrt{R^2 + (X_L - X_C)^2}$$

It is called the impedance in an a. c. circuit. From the figure,

$$\tan \phi = \frac{V_L - V_C}{V_R}$$

$$= \frac{I_0 X_L - I_0 X_C}{I_0 R}$$

$$\tan \phi = \frac{X_L - X_C}{R}$$

$$\rightarrow \phi = \tan^{-1} \left( \frac{X_L - X_C}{R} \right)$$

**Condition :** The current will be in phase with the voltage at resonance condition.

At resonance condition,

$$X_L = X_C$$

$$\omega L = \frac{1}{\omega C}$$

$$\omega = \frac{1}{\sqrt{LC}}$$

$$2\pi f = \frac{1}{\sqrt{LC}}$$

$$f = \frac{1}{2\pi\sqrt{LC}}$$

(b) As  $\cos \phi = \frac{R}{Z}$

In LR circuit,  $P_1 = \cos \phi$

$$P_1 = \frac{R}{\sqrt{R^2 + X_L^2}} = \frac{R}{\sqrt{2R^2}} \quad [X_L = R]$$

$$P_1 = \frac{1}{\sqrt{2}}$$

In LCR circuit when,  $X_L = X_C$

$$P_2 = \frac{R}{\sqrt{R^2 + (X_L - X_C)^2}}$$

$$= \frac{R}{R} = 1 \quad [X_L = X_C]$$

$$\therefore \frac{P_1}{P_2} = \frac{1}{\sqrt{2}}$$

OR

(a) A transformer is an electrical device for converting an alternating current at low voltage into high voltage or vice-versa.

1. If it increases the input a.c. voltage and decreases the, it is called step up transformer.
2. If it decreases the input a.c. voltage and increases the current, it is called step down transformer.

**Principle :** It works on the principle of mutual induction *i.e.*, when a changing current or flux is passed through one of the two inductively coupled coils, an induced emf is set up in the other coil.

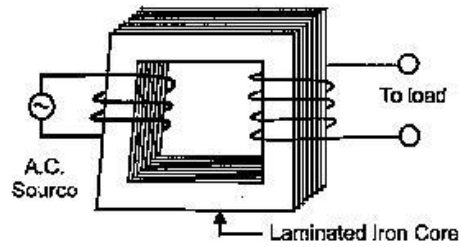

Step-up transformer

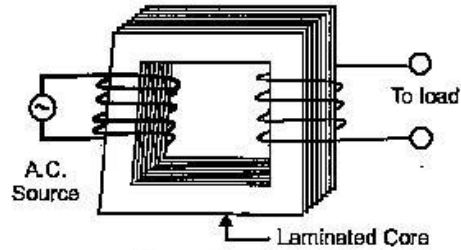

Step-down transformer

**Working Theory :** As the a.c. flows through the primary, it generate an alternating magnetic flux in the core which passes through the secondary coil.

Let  $N_1$  = No. of turns in primary coils

$N_2$  = No. of turns in secondary coils

This changing flux set up an induced emf in the secondary, also a self induced emf in the primary.

If there is no leakage of magnetic flux, then flux linked with each turn of the primary will be equal to that linked with each of the secondary. According to Faraday's law of induction

Induced emf in the primary coil,  $\epsilon_1 = -N_1 \frac{d\phi}{dt}$

Induced emf in the secondary coil,  $\epsilon_2 = -N_2 \frac{d\phi}{dt}$

where,  $\frac{d\phi}{dt}$  = Rate of change of magnetic flux associated with each turn.

$\phi$  = Magnetic flux linked with each turn of the primary or secondary at any instant.

$$\frac{\epsilon_2}{\epsilon_1} = \frac{N_2}{N_1}$$

Energy losses in transformer :

1. **Copper loss :** Some energy is lost due to the heating of copper wires used in the primary and secondary windings. This power loss ( $P = I^2R$ ) can be minimised by using thick copper wires of low resistance.
2. **Eddy current loss or Iron loss :** The alternating magnetic flux induces eddy current in the iron core which leads to some energy loss in

the form of heat. This loss can be reduced by using laminated iron core.

3. **Hysteresis loss** : When the iron core is subjected to a cycle of magnetisation the core gets heated up due to hysteresis, having low hysteresis loop.
4. **Flux leakage** : The magnetic flux produced by the primary may not fully pass through the secondary. Some of the flux may leak into air. This loss can be minimised by winding the primary and secondary coils over one another.

(b) Given,  $N_1 = 100$   
 $K = 100$   
 $V_1 = 220 \text{ V}$   
 $P_1 = 1100 \text{ W}$

(i) As,  $K = \frac{N_2}{N_1}$   
 $N_2 = KN_1 = 100 \times 100$   
 $N_2 = 10000$

(ii)  $P_1 = V_1 I_1$   
 $I_1 = \frac{P_1}{V_1} = \frac{1100}{220} = 5 \text{ A}$

(iii)  $\frac{V_2}{V_1} = K$   
 $V_2 = KV_1; V_2 = 100 \times 220$   
 $V_2 = 22000 \text{ V}$

(iv)  $\frac{I_1}{I_2} = K$   
 $I_2 = \frac{I_1}{K} = \frac{5}{100}$   
 $I_2 = 0.05 \text{ A}$

(v)  $P_2 = V_2 I_2$   
 $P_2 = 22000 \times \frac{5}{100}; P_2 = 1100 \text{ W}$

25. (a) In Young's double slit experiment, deduce the condition for (i) constructive, and (ii) destructive interference at a point on the screen. Draw a graph showing variation of intensity in the interference pattern against position 'x' on the screen.
- (b) Compare the interference pattern observed in Young's double slit experiment with single slit diffraction pattern, pointing out three distinguishing features. [3]

OR

- (a) Plot a graph to show variation of the angle of deviation as a function of angle of incidence for light passing through a prism. Derive an expression for refractive index of the prism in terms of angle of minimum deviation and angle of prism.
- (b) What is dispersion of light? What is its cause?
- (c) A ray of light incident normally on one face of a right isosceles prism is totally reflected as shown in fig. What must be the minimum value of refractive index of glass? Give relevant calculations.

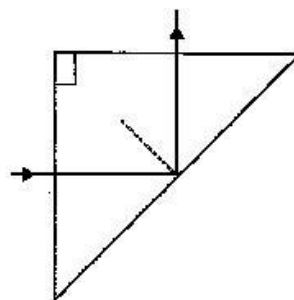

**Answer :** (a) Let the two waves arising from the slits A and B have the amplitudes  $a$  and  $b$  and the phase difference  $\phi$ . Such that  $y_1 = a \sin \omega t$  and  $y_2 = b \sin (\omega t + \phi)$ .

The resultant displacement is given as :

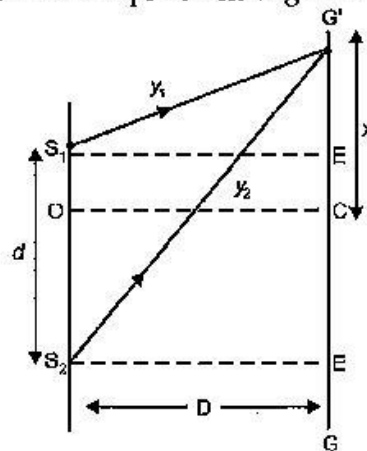

$$y = y_1 + y_2$$

$$y = a \sin \omega t + b \sin (\omega t + \phi)$$

$$y = a \sin \omega t + b \sin \omega t \cos \phi + b \cos \omega t \sin \phi$$

$$y = (a + b \cos \phi) \sin \omega t + b \sin \phi \cos \omega t \quad \dots(i)$$

Let  $a + b \cos \phi = A \cos \delta \quad \dots(ii)$

and  $b \sin \phi = A \sin \delta \quad \dots(iii)$

Hence,  $y = A \sin \omega t \cos \delta + A \cos \omega t \sin \delta$

$$y = A \sin (\omega t + \delta) \quad \dots(iv)$$

Where the amplitude  $A$  of the resultant wave can be given as:

$$A = \sqrt{a^2 + b^2 + 2ab \cos \phi} \quad \dots(v)$$

and  $\tan \delta = \frac{b \sin \phi}{a + b \cos \phi} \quad \dots(vi)$

(i) **Constructive interference** : Intensity  $I \propto A^2$  and for  $A$  to be maximum

$$\cos \phi = 1$$

or  $\cos \phi = \cos 2n\pi, n = 0, 1, 2, 3, \dots$

$$\phi = 2n\pi \quad \dots(i)$$

and path difference

$$\Delta x = n\lambda \quad \dots(ii)$$

$$A_{\max} = a + b$$

$$I \rightarrow I_{\max} = k(a + b)^2$$

(ii) **Destructive interference** : For  $I$  to be minimum

$$\cos \phi = -1$$

Phase difference :

$$\Delta \phi = (2n + 1)\pi$$

and path difference :

$$\Delta x = (2n + 1) \frac{\lambda}{2}$$

$$A_{\min} = a - b$$

$$I \rightarrow I_{\min} = k(a - b)^2$$

Graph showing interference pattern against position ' $x$ ' on the screen.

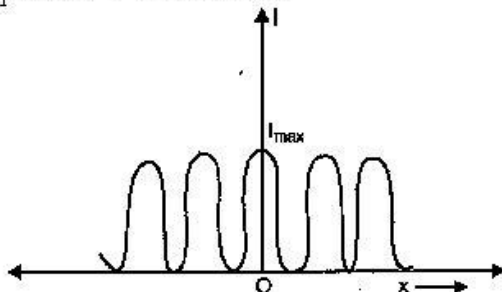

(b) Comparison of interference pattern observed in Young's double slits and the single slit diffraction :

S. No.	Interference	Diffraction
1.	Interference is the result of superposition of secondary waves starting from two different wave fronts originating from two coherent sources.	Diffraction is the result of superposition of secondary waves starting from different part of same wavefront.
2.	All bright and dark fringes are of equal width.	The width of central bright fringe is twice the width of any secondary maximum.

3.	All bright fringes are of same intensity	Intensity of bright fringes decreases as we move away from central bright fringes on either side.
----	--	---

OR

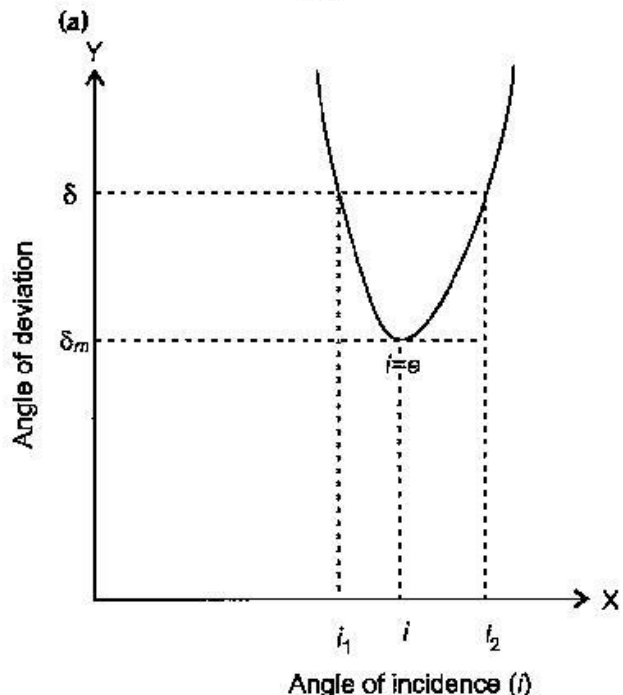

From figure,  $\delta = \delta_m, i = e$  which implies  $r_1 = r_2$

$$2r = A, \text{ or } r = A/2$$

Using

$$\delta = i + e - A$$

$$\delta_m = 2i - A$$

$$i = \frac{A + \delta_m}{2}$$

$$\mu = \frac{\sin i}{\sin r} = \frac{\sin \left( \frac{A + \delta_m}{2} \right)}{\sin A/2}$$

(b) **Dispersion of light** : Dispersion is often observed as light passes through a triangular prism. Upon passing through the prism, the white light is separated into its component colours : red, orange, yellow, green, blue, and violet. The separation of visible light into its different colours is known as dispersion. Dispersion occurs because for different colour of light a transparent medium will have different refractive indices ( $\mu$ ), as different colours have different speed in transparent medium.

(c) For total internal reflection :

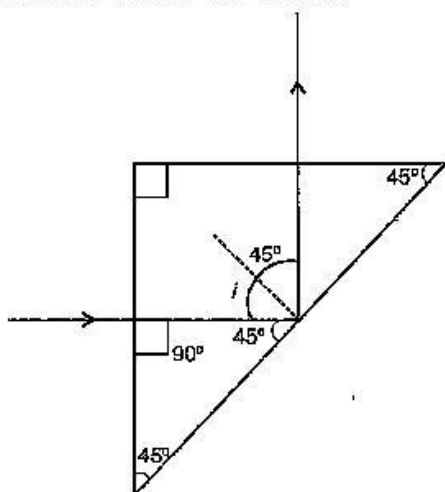

$$\begin{aligned}
 i &\geq Q_c \\
 \sin i &\geq \sin Q_c \\
 \sin 45^\circ &\geq \frac{1}{\mu} \\
 \frac{1}{\sqrt{2}} &\geq \frac{1}{\mu} \\
 \mu &\geq \sqrt{2} \\
 \mu_{\min} &= \sqrt{2}
 \end{aligned}$$

26. (a) Define the term drift velocity.  
 (b) On the basis of electron drift, derive an expression for resistivity of a conductor in terms of number density of free electrons and relaxation time. On what factors does resistivity of a conductor depend ?  
 (c) Why alloys like constantan and manganin are used for making standard resistors ? [5]  
 OR  
 (a) State the principle of working of a potentiometer.  
 (b) In the following potentiometer circuit AB is a uniform wire of length 1 m and resistance 10  $\Omega$ . Calculate the potential gradient along the wire and balance length AO (= l).

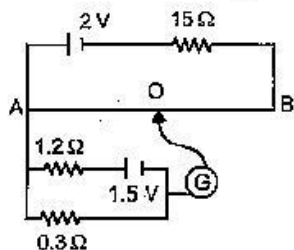

**Answer :** (a) Drift velocity is defined as the average velocity with which the free electrons are drifted towards the positive terminal under the effect of applied electric field. Thermal velocities are randomly distributed and average thermal velocity is zero.

$$\vec{u}_1 + \vec{u}_2 + \dots + \vec{u}_N = 0$$

$$\text{i.e. } v_d = -\frac{eE\tau}{m}$$

(b) We know that the current flowing through the conductor is :

$$I = nAev_d$$

$$\therefore I = neA \left( -\frac{eE\tau}{m} \right)$$

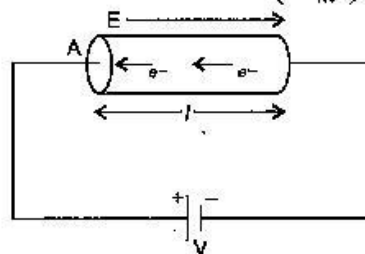

$$\begin{aligned}
 \text{Using } E &= \frac{V}{l} \\
 I &= neA \left( \frac{eV}{ml} \right) \tau \\
 &= \left( \frac{ne^2 A \tau}{ml} \right) V = \frac{1}{R} V
 \end{aligned}$$

$I \propto V \rightarrow$  by Ohm's law

Where,  $R = \frac{ml}{ne^2 A \tau}$  is a constant for a particular conductor at a particular temperature and is called the resistance of the conductor.

$$R = \left( \frac{m}{ne^2 \tau} \right) \frac{l}{A} = \frac{\rho l}{A}$$

$$\rho = \left( \frac{m}{ne^2 \tau} \right)$$

Where  $\rho$  is the specific resistance or resistivity of the material of the wire. It depends on number of free electron per unit volume and temperature.

- (c) They are used to make standard resistors because :
1. They have high value of resistivity.
  2. Temperature coefficient of resistance is less.
  3. They are least affected by temperature.

OR

(a) **Principle of potentiometer :** The basic principle of potentiometer is that when a constant current flows through a wire of uniform cross-section area then the potential drop across any length of the wire is directly proportional to that length.

A potentiometer is a device used to measure an unknown emf or potential difference and

internal resistance of a cell accurately.

(b) Total resistance of the primary circuit = 15  
+ 10 = 25  $\Omega$ ,

$$\text{emf} = 2 \text{ V}$$

$\therefore$  Current in the wire AB

$$I = \frac{2}{25} = 0.08 \text{ A}$$

P. D. across the wire AB = Current  $\times$  Resistance  
of wire AB

$$= 0.08 \times 10 = 0.8 \text{ V}$$

$$\text{Potential gradient} = \frac{\text{P.D.}}{\text{Length}} = \frac{0.8}{100}$$
$$= 0.008 \text{ V cm}^{-1}$$

Resistance of secondary circuit  
= 1.2 + 0.3 = 1.5  $\Omega$

$$\text{emf} = 1.5 \text{ V}$$

$$\text{Current in the secondary circuit} = \frac{1.5}{1.5} = 1.0 \text{ A}$$

The same is the current in 0.3  $\Omega$  resistor.

P. D. between points A and O,

P. D. across 0.3  $\Omega$  resistor in the zero-deflection  
condition.

$$= \text{Current} \times \text{Resistance}$$

$$= 1.0 \times 0.3 = 0.3 \text{ V}$$

$$\text{Length AO} = \frac{\text{Potential difference}}{\text{Potential gradient}}$$

$$= \frac{0.3 \text{ V}}{0.008 \text{ V cm}^{-1}} = 37.5 \text{ cm}$$

●●



